



DIN300 300E

Features

- 25 selectable sensitivity settings: 30 mA to 30 A
- 9 selectable time delays: 0 to 3s
- Earth leakage level indicators
- Detection of no connection to ZCT
- Relay tripped indicator
- Trip starting indicator
- Protected against nuisance tripping

Features For DIN 300E only

- 50% pre-fault output contact
- Remote test and remote reset functions 

Technical Data

AUXILIARY SUPPLY

Model DIN300 / 300E -240A	: 198 ~ 265 V AC
Model DIN300 / 300E -110A	: 94 ~ 127 V AC
Rated frequency	: 50 / 60 Hz
VA rating	: 3 VA typical

SETTING RANGES

Sensitivity setting	: 30 mA, 50 mA, 75 mA, 100 mA, 125 mA, 150 mA, 200 mA, 250 mA, 300 mA, 500 mA, 750 mA, 1 A, 1.25 A, 1.5 A, 2 A, 2.5 A, 3 A, 5 A, 7.5 A, 10 A, 12.5 A, 15 A, 20 A, 25 A, 30 A.
Time delay setting	: Instantaneous, 50 ms, 100 ms, 150 ms, 250 ms, 350 ms, 500 ms, 1 s, 3 s.

PERFORMANCE

Setting accuracy	: -15% to +0%
Timing accuracy	: ±5%

OUTPUT CONTACTS

Contacts (Trip / 50% pre-fault*)	
Rated voltage	: 250 V AC
Contact rating	: 5 A
Expected electrical life	: 100,000 operations at rated current
Expected mechanical life	: 5 x 10 ⁶ operations

INPUT

Remote test* / Reset inputs*	: N.O. dry contacts
------------------------------	---------------------

ZERO - PHASE CURRENT TRANSFORMER

To operate with Mikro's ZCT series of current transformer

INDICATORS

Auxiliary supply	: Green indicator
Time delay	: Red indicator
Trip	: Red indicator
Leakage current* leakage levels	: 5 red indicators for

ENVIRONMENTAL CONDITIONS

Temperature	: -10°C to 55°C
Humidity	: 5% to 95%, non-condensing

MECHANICAL

Mounting	: DIN rail mounting
Dimension (mm)	: 71(w) x 85(h) x 70(d)
Approximate weight	: 0.4 kg (excluding ZCT)

* Applicable to DIN300E model only

Typical Application Diagram For DIN 300

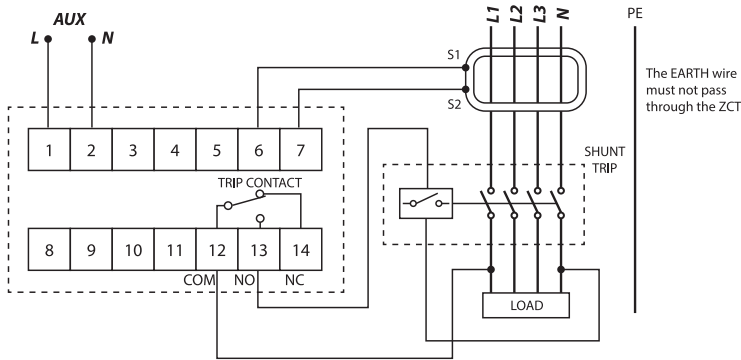

Typical Application Diagram For DIN 300E

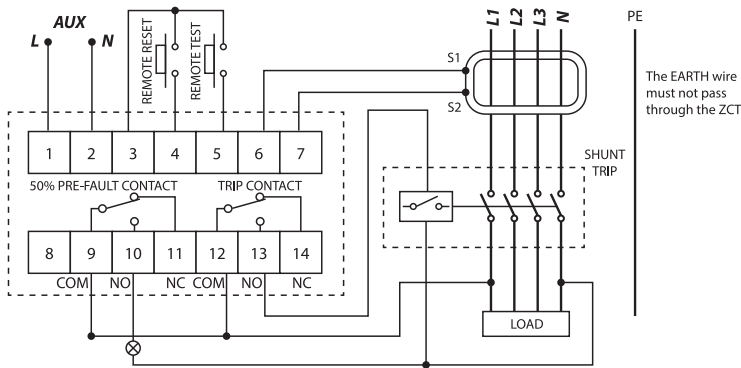

Case Dimensions

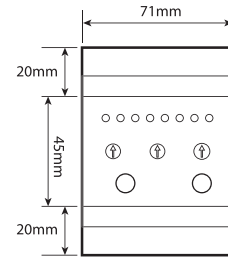

Front view

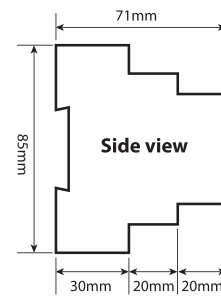

Side view

Ordering Information

MODEL	DESCRIPTION
DIN300 - 240A	For 50 Hz system, auxiliary voltage 240 V AC
DIN300 - 110A	For 50 Hz system, auxiliary voltage 110 V AC
DIN300E - 240A	For 50 Hz system, auxiliary voltage 240 V AC
DIN300E - 110A	For 50 Hz system, auxiliary voltage 110 V AC
DIN300 - 240A6	For 60 Hz system, auxiliary voltage 240 V AC
DIN300 - 110A6	For 60 Hz system, auxiliary voltage 110 V AC
DIN300E - 240A6	For 60 Hz system, auxiliary voltage 240 V AC
DIN300E - 110A6	For 60 Hz system, auxiliary voltage 110 V AC