



Digital Power Meter User Manual
RX380



MyHP00305/23

HAZARD CATAGORIES AND SPECIAL SYMBOL

Read all instruction carefully and check the device before installing or servicing it. The following safety alert symbol may appear throughout this manual or on the device to warn of any potential hazards or to call for attention.



PLEASE NOTE

The power meter should be installed, operated, serviced and maintained only by qualified personnel. No responsibility is assumed by the manufacturer for any consequences arising out of the use of this material.

DISCLAIMER

Mikro shall not be liable for errors contained herein including any incidental and/or consequential damages arising from the use of this material. Mikro also reserves the right to vary the product from that described in this material without prior notice.

COPYRIGHT

The licensed software contained in the product is proprietary software owned by Mikro or its third party suppliers and shall be used solely in connection with the product.

BEFORE YOU BEGIN

- Apply appropriate personal protective equipment and follow safe electrical work practices.
- NEVER work alone.
- Turn off all power supplying the power meter and the equipment in which it is installed before working on it.
- Always use a properly rated voltage sensing device to confirm that all power is off.
- Before closing all covers and doors, carefully inspect the work area for tools and objects that may have been left inside the equipment.
- NEVER bypass external fusing.
- NEVER open circuit a CT; use the shorting block to short circuit the leads of the CT before removing the connection from the power meter.
- Before performing hi-pot testing on any equipment in which the power meter is installed, disconnect all input and output wires to the power meter. High voltage testing may damage electronic components contained in the power meter.
- The power meter should be installed in a suitable electrical enclosure.

Failure to follow this instruction may result in serious injury

CONTENTS

1. Introduction	1
1.1. Content of box	1
1.2. Part of power meter	2
2. Installation Guide	3
2.1. Precautions	3
2.2. Mounting	3
2.3. Wiring	4
3. Meter parameters	6
4. Display and Buttons	6
5. Function	7
6. Setting up	9
6.1. Access programming mode	9
6.2. Setup CT ratio	10
6.3. Setup PT ratio	10
6.4. Neutral current	11
6.5. Setup communication configuration	11
6.6. Demand setting	12
6.7. System setting	12
6.8. Reset all energy register	13
6.9. Reset demand register	13
6.10. Reset maximum & minimum value	14
6.11. Remote set	14
6.12. Scroll setting	15
6.13. Scroll delay setting	15
6.14. Reset Hour on register	16
6.15. Backlight setting	16
6.16. Software version	16
6.17. Exit from programming mode	17
6.18. Setup new password	17
7. Specifications	18
8. Modbus Data Register	20

9. Maintenance and Troubleshooting	31
10. Dimensions	31
11. Appendix	32
11.1. Demand Calculation	32
11.2. Data Read Format from Modbus	32
11.3. Neutral Current Calculation	33

FIGURES

1. Parts of power meter	2
2. Recommended cut-out	3
3. 3-phase 4-wire system with 4 CTs	4
4. 3-phase 4-wire system with 3 CTs	4
5. 3-phase 3-wire with 3CTs and 3VTs	5
6. 3-phase 3-wire with 2CTs and 3VTs	5
7. Menu map for the normal mode	7
8. Flow map for the programming mode	8

TABLE

1. Parts list	1
2. Location and part label	2
3. Model information	2
4. Specification	18
5. Data length nomenclature	20
6. Device and communication register	20
7. Operation data registers	21
8. Setting data registers	30

1. Introduction

Thank you for purchasing the RX380 Digital Power Meter. This multifunctional power meter measures the following parameters:

- True RMS phase voltage (L - N)
- True RMS line voltage (L - L)
- True RMS phase and neutral current
- Positive and negative maximum and minimum active and reactive power
- Maximum and minimum apparent power
- Total active, reactive and apparent energy
- Total and displacement power factor
- Frequency
- Voltage and current total harmonic distortion (THD)
- Phase Voltage and Current harmonic
- Demand and maximum demand for total real, reactive and apparent power
- Maximum and minimum phase and line voltage
- Maximum and minimum phase and neutral current
- Positive and negative maximum and minimum total active, reactive and apparent power

This power meter also comes with the Modbus-RTU connectivity.

1.1. CONTENT OF BOX

Upon opening this box, you should find the following item shown in table 1:

Table 1: Parts list

No	Description	Quantity
1	RX380 power meter	1
2	Retainer clip	2
3	Quick guide	1

1.2. PARTS OF POWER METER

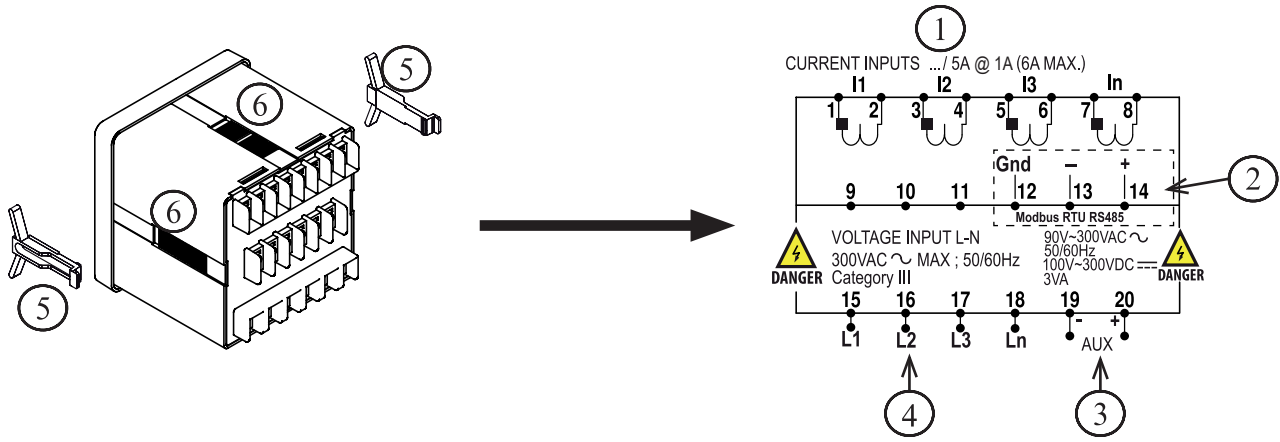

Figure 1: Parts of power meter

Table 2: Location and part label

No	Part	Description
1	Current inputs	Current metering connections
2	RS485 port	The RS485 port is used for communications with remote monitoring and control system
3	Power supply input	Connection to power the meter
4	Voltage inputs	Voltage metering connections
5	Retainer clips	Used to hold power meter in place.
6	Retainer clips slot	To slot-in retainer clips in place

Table 3: Model information

Model Information	
RX380	Auxiliary 90~300VAC or 100~300VDC; with Modbus

2. Installation Guide

2.1. PRECAUTIONS



Before installing the power meter, please check that the environment meets the following condition:

- Operating temperature -10 Celcius to +55 Celcius.
- Humidity 5% to 95%, non-condensing
- Dust free environmental away from electrical noise and radiation

2.2. MOUNTING

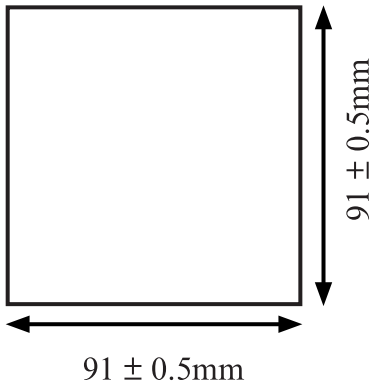

Figure 2:
Recommended cut-out.

a) Provide a cut out hole on the switchgear panel according to the dimension below.

b) Insert the power meter through the hole and slide in the retainer clip along the slots on left and right sides or bottom and top sides of the power meter until the device is tightly secured on the switchgear panel. The orientation of the retainer clips is shown in Figure 1. The retainer clip can be removed by lifting the tab lightly at the handle end.

c) Connect the metering voltage input, current input, communication and auxiliary according to the wiring schemes shown in Section 2.3, Figure 3 to 6 on the next page.

d) The recommended wire size is as below:

- Voltage input and auxiliary - AWG16~22
- Current input - AWG12~18
- Modbus-RTU - AWG22 or thicker, shielded twisted pair



NOTE:

Polarity marks must be followed as shown for CTs (S1 and S2). Please make sure the power to the current metering input is totally shunted. Under no circumstances can the CT connection be left in open circuit. Use a CT shorting block if necessary.

e) When connecting the power meter, please make sure the polarity to the terminal is correctly aligned.

f) If the Modbus-RTU is used, it can be connected up to 32 devices in a daisy chain fashion and the cable total length should not be more than 1000m.



NOTE:

For Modbus-RTU connection, avoid running the cable near sources of electrical noise. The network cable shield should be grounded at only one end.

2.3. WIRING

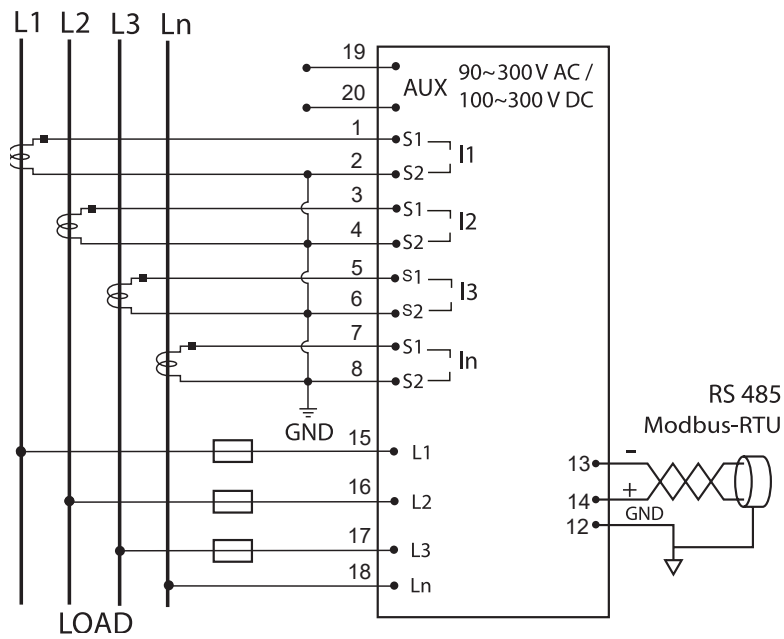

Figure 3: 3 Phase 4-Wire System with 4CTs connection, direct voltage input.

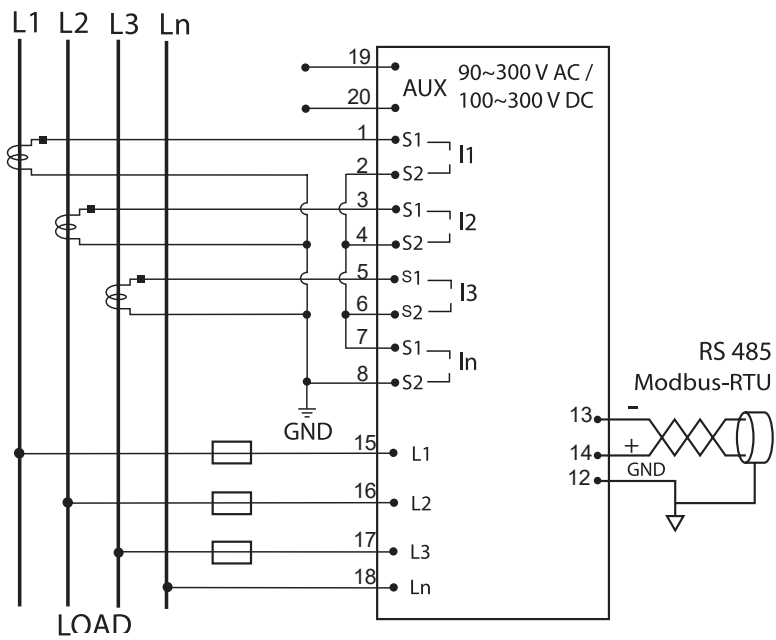

Figure 4: 3-Phase 4-Wire System with 3CTs connection, direct voltage input.

NOTE:

Neutral current measurement is based on the vector sum of 3 CTs.

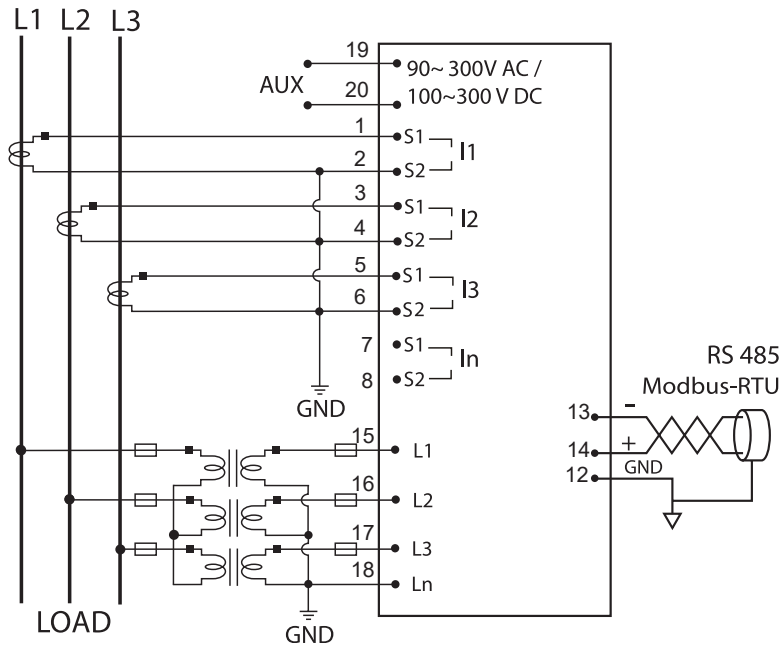

Figure 5 : 3-phase 3-wire with 3CTs and 3VTs connection.

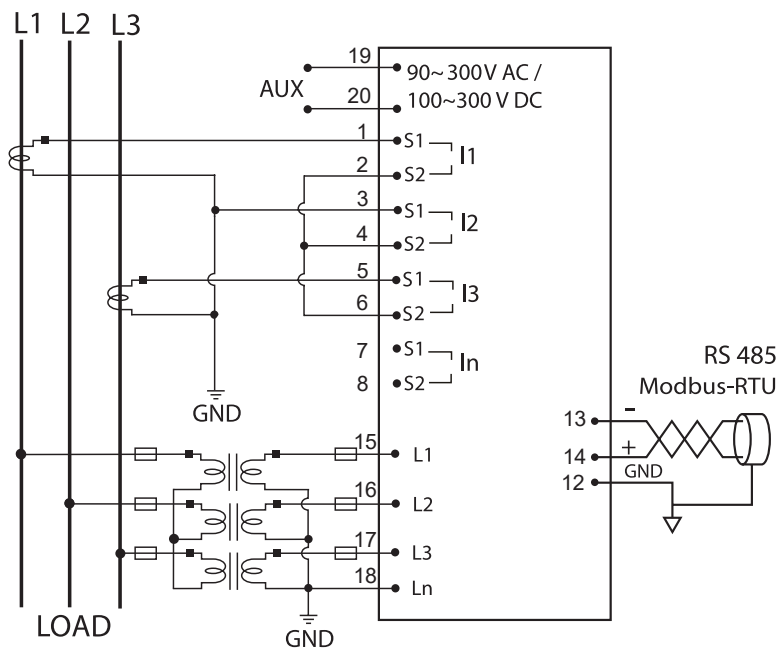

Figure 6: 3-phase 3-wire with 2CTs and 3VTs connection.

NOTE:

I2 current measurement is based on the vector sum of 2 CTs.

3. Meter parameters

Before commencing operation, the meter has to be set up. To do this, the meter must be powered up by the meter control power supply.

Under Section 6, the following parameters should be reviewed against the default value if necessary:

- CT Ratio
- PT Ratio
- Neutral current input
- Modbus-RTU setting
- Demand setting
- System setting
- Remote Set
- Scroll mode setting and delay time
- Backlight setting

The flow maps for the meter is under Section 5. It is guideline for the user to flip to the desire window whether in normal mode or programming mode.

4. Display and Buttons

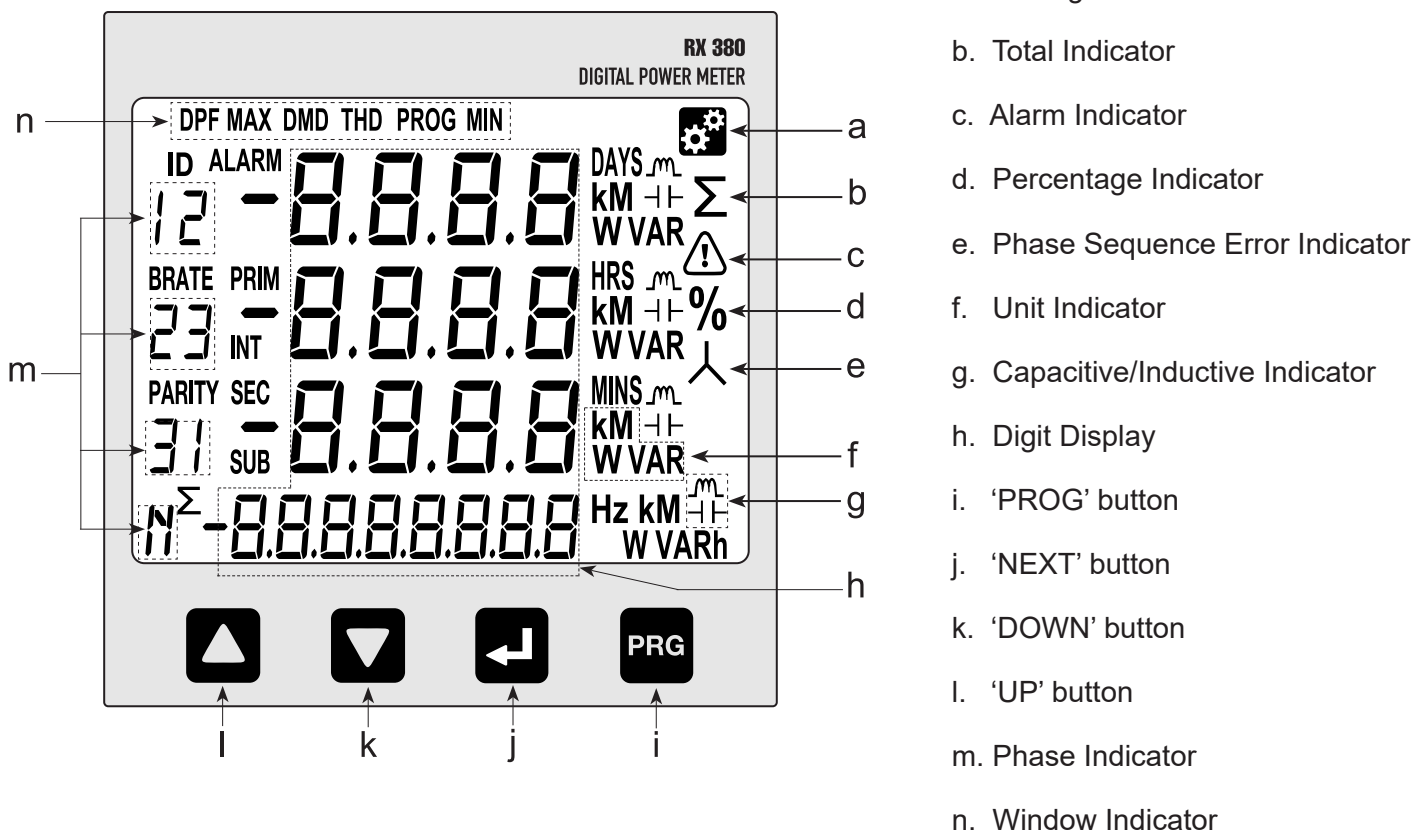

NOTE:

In case of current/voltage phase loss or phase sequence error, both Alarm Indicator (c) and Phase Sequence Error Indicator (e) will blink

5. Function

Figure 7 below shows menu map for the power meter. It includes the setting and measurement display for the power meter. These menus can be accessed by pressing NEXT, UP, PROG & DOWN buttons.

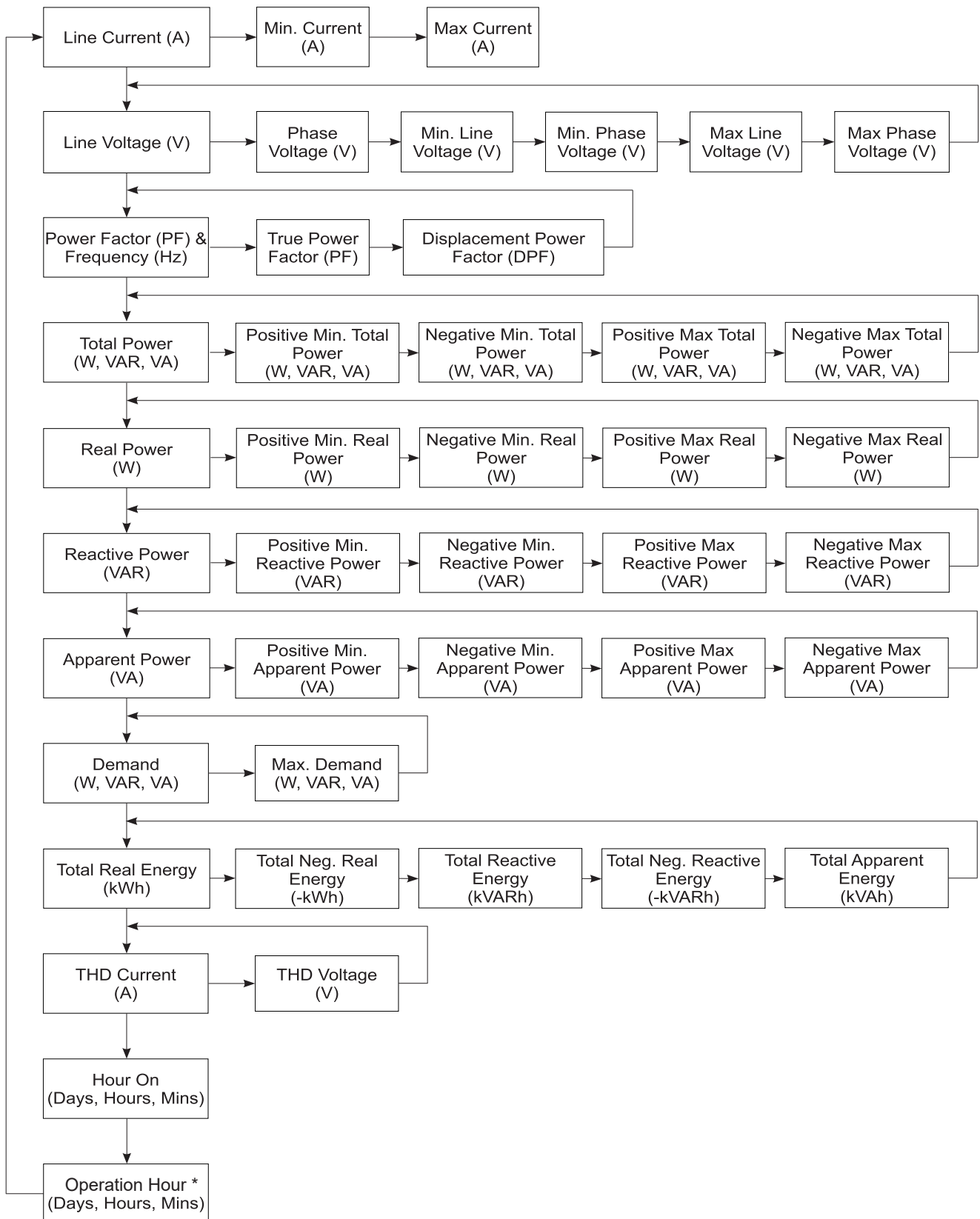

*Only available on firmware version A2.12 and above

Figure 7 : Menu map for normal mode.

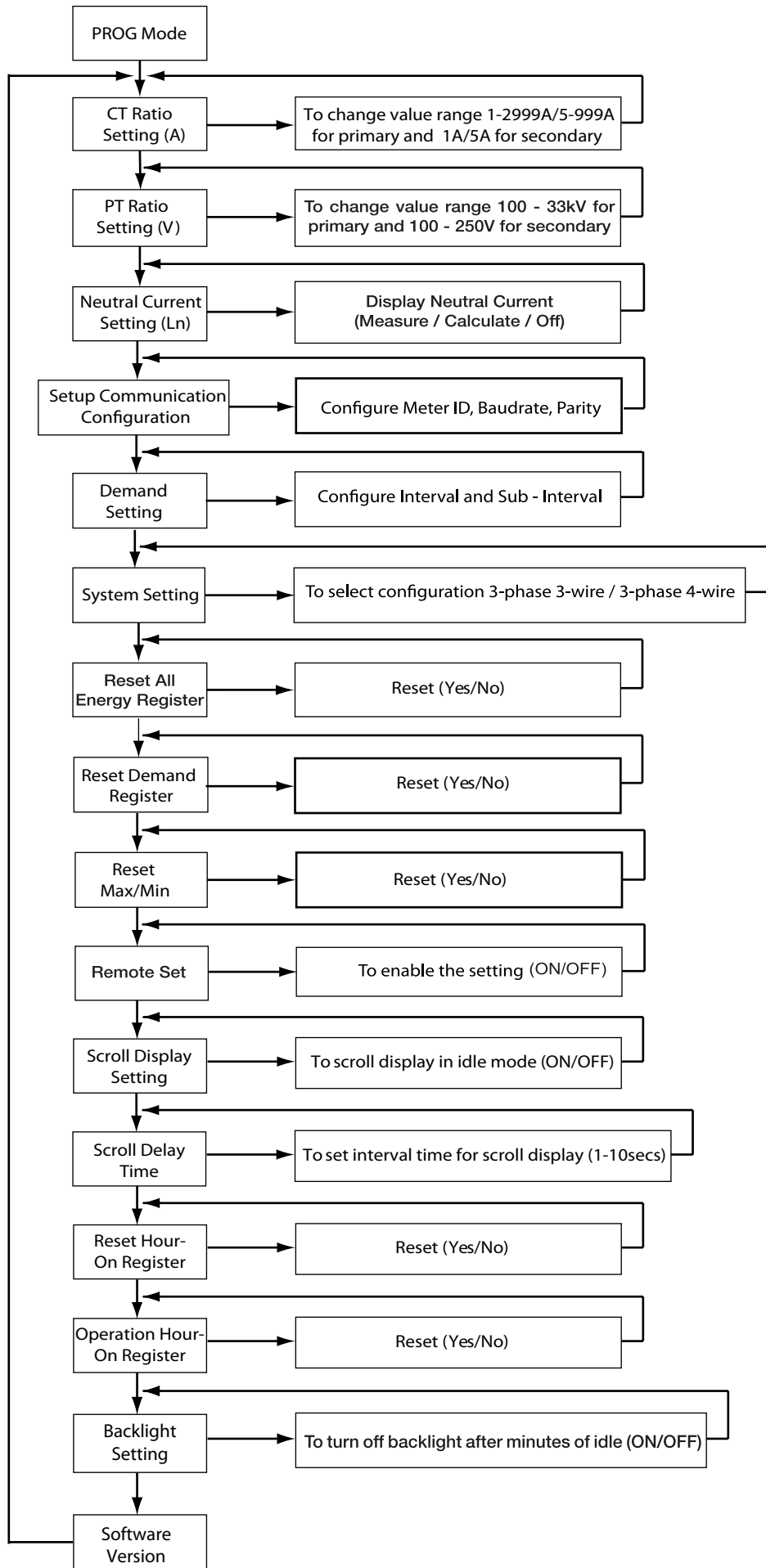
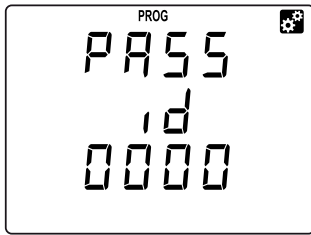

Figure 8 : Menu map for programming mode

6. Setting up

The power meter comes with factory default settings. These values may be changed by navigating to the appropriate screens and entering new values. Use the instructions in the following sections to change the values.

6.1. ACCESS PROGRAMMING MODE



- Press the PROG button to enter programming mode. The first number will blink to enter password.
- Use the UP or DOWN button to change display value and the NEXT button to shift to next number.
- Press the PROG button to confirm and enter programming mode. Setup CT ratio will be display. If the password is incorrect, the meter will return to normal mode.
- To exit press the PROG button and display will return to normal mode.

NOTE:

Default password is "0000"

6.2. SETUP CT RATIO

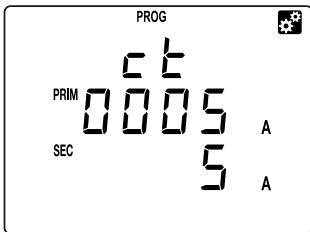

- CT ratio setting is the first item displayed in programming mode.
- Press the NEXT button to change. The first digit will blink.
- Use the UP or DOWN button to change the primary CT value.
- Press the NEXT button for the next digit. Repeat step (b) & (c) to change, or else press PROG button to save the setting.
- To change the secondary CT between 5A and 1A press the next button until secondary CT value blink. *
- The SAVE window will be prompted. Use the UP or DOWN button to select "YES" or "NO". Press the PROG button to confirm.
- To proceed next setting press DOWN button. To exit programming mode, press the PROG button. Refer Section 6.17.

*Only available on firmware version A2.12 and above

NOTE:

CT Ratio default value is 5/5A

6.3. SETUP PT RATIO

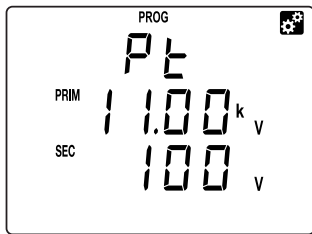

- Scroll in programming mode until “Pt” is displayed using the UP or DOWN button.
- This parameter is to change the PT value if the Power Transformer (PT) is connected.
- Press the NEXT button to change. The “V” symbol for primary will blink.
- Press the UP or DOWN button to change the value of setting.
- Press the NEXT button to confirm the new setting and proceed for secondary setting.
- Repeat step (c) & (d) to change for secondary. Once confirmed, press the NEXT button again.
- The SAVE window will be prompted. Press the UP or DOWN button to select “YES” or “NO”. Press the PROG button to confirm.
- Use the DOWN button to scroll to next setting.
- To exit programming mode, refer Section 6.17.

NOTE:

PT Ratio default value is 100/100V

6.4. NEUTRAL CURRENT

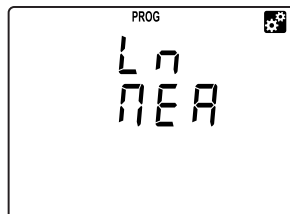
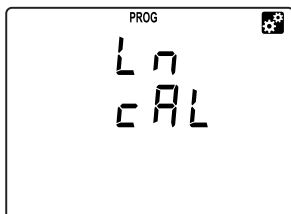
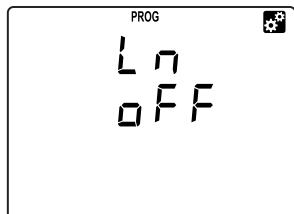

- Scroll in programming mode until “Ln” is displayed using the UP or DOWN button.
- This parameter is to display neutral current if the neutral current (Ln) is connected.
- Press the NEXT button to change. The “PROG” symbol will blink.
- Press the UP or DOWN button to toggle the symbol “cAL” for calculated value, “MEA” for measured value or “OFF” to disable.
- Press the NEXT button to confirm the new setting.
- The SAVE window will be prompted. Press the UP or DOWN button to select “YES” or “NO”. Press the PROG button to confirm.
- Use the DOWN button to scroll to next setting.
- To exit programming mode, refer Section 6.17.

NOTE:

Neutral current default setting is measured value

6.5. SETUP COMMUNICATION CONFIGURATIONS

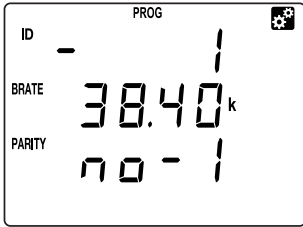

- Scroll until "ID BRATE PARITY" is displayed using the UP or DOWN button.
- Press the NEXT button. The "PROG" and "-" symbol next to "ID" will blink. Use the UP or DOWN button to change the device ID.
- Next, press the NEXT button and "-" symbol next to "BRATE" will blink to change baudrate. Repeat step (b) to change.
- Press NEXT button to change parity and "-" symbol next to "PARITY" will blink. Repeat step (b) to change.
- Then press the NEXT button to confirm new setting.
- The SAVE window will be prompted. Press the UP or DOWN button to select "YES" or "NO". Press the PROG button to confirm.
- Use the DOWN button to scroll to next setting.
- To exit programming mode, refer Section 6.17.

NOTE:

Default value for the communication ID is 1, baudrate is 38400 bps and parity set to no-1 (parity none, stop bit 1).

6.6. DEMAND SETTING

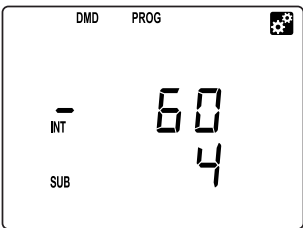

- Scroll until "DMD" is displayed using the UP or DOWN button.
- Press the NEXT button to change interval value. The "PROG" symbol will displayed and "-" symbol next to "INT" will blink.
- Use UP or DOWN button to change value and press NEXT button to confirm and change sub-interval setting. The "-" symbol next to "SUB" will blink. Press UP or DOWN button to change and NEXT button to confirm.
- The SAVE window will be prompted. Press the UP or DOWN button to select "YES" or "NO". Press the PROG button to confirm.
- Use the DOWN button to scroll to next setting
- To exit programming mode, refer Section 6.17.

NOTE:

Demand setting default value is 60/4

6.7. SYSTEM SETTING

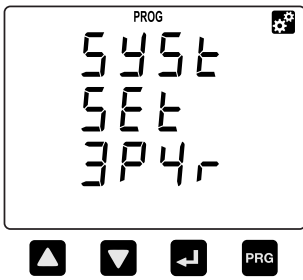

- Scroll in programming mode until "SYSt sEt" is displayed using the UP or the DOWN button.
- Press the NEXT button. The "PROG" symbol will blink. Use the UP or DOWN button to toggle 3-phase 4-wire "3P4r" or 3-phase 3-wire "3P3r" symbols.
- Press the NEXT button to confirm new setting.
- The SAVE window will be prompted. Press the UP or DOWN button to select "YES" or "NO". Press the PROG button to confirm.
- Use the DOWN button to scroll to next setting.
- To exit programming mode, refer Section 6.17.

NOTE:

System setting default value is 3-phase 4-wire

6.8. RESET ALL ENERGY REGISTER

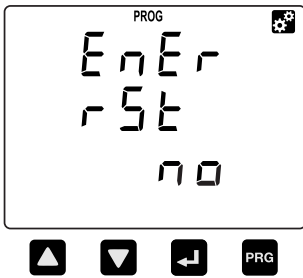

- Scroll in programming mode until "EnEr rSt" is displayed using the UP or the DOWN button.
- Press the NEXT button. The "PROG" symbol will blink. Use the UP or DOWN button to toggle "yES" or "no" symbols.
- To abort clearing energy register values, select "no". To clear all energy values select "yES".
- Press the NEXT button to confirm the new setting.
- The rSt dAtA window will be prompted. Press the UP or DOWN button to select "YES" or "NO". Press the PROG button to confirm.
- Use the DOWN button to scroll to next setting.
- To exit programming mode, refer Section 6.17.

6.9. RESET DEMAND REGISTER

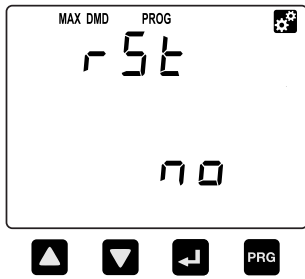

- Scroll in programming mode until "dMd rSt" is displayed using the UP or the DOWN button.
- Press the NEXT button. The "PROG" symbol will blink. Use the UP or DOWN button to toggle "yES" or "no" symbols.
- To abort clearing demand register, select "no". To clear all demand register select "yES".
- Press the NEXT button to confirm the new setting.
- The rSt dAtA window will be prompted. Press the UP or DOWN button to select "YES" or "NO". Press the PROG button to confirm.
- Use the DOWN button to scroll to next setting.
- To exit programming mode, refer Section 6.17.

6.10. RESET MAXIMUM AND MINIMUM VALUE



- Scroll until "rSEt" is displayed using the UP or the DOWN button.
- Press the NEXT button. The "PROG" symbol will blink. Use the UP or DOWN button to toggle "yES" or "no" symbols.
- To abort clearing max. and min. values, select "no". To clear all max. and min. values select "yES".
- Press the NEXT button to confirm new setting.
- The rSt dAtA window will be prompted. Press the UP or DOWN button to select "YES" or "NO". Press the PROG button to confirm.
- Use the DOWN button to scroll to next setting.
- To exit programming mode, refer Section 6.17.

6.11. REMOTE SET

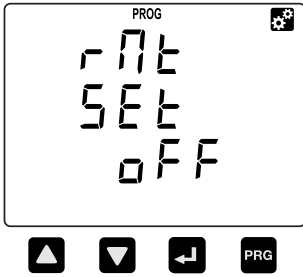

- Scroll until "rMt SEt" is displayed using the UP or the DOWN button.
- Press the NEXT button. The "PROG" symbol will blink. Use the UP or DOWN button to toggle Enable "on" or disable "oFF" symbols.
- Press the NEXT button to confirm new setting.
- The SAVE window will be prompted. Press the UP or DOWN button to select "YES" or "NO". Press the PROG button to confirm.
- Use the DOWN button to scroll to next setting.
- To exit programming mode, refer Section 6.17.

NOTE:

Enabling the remote set allows the remote terminal to read and write the meter setting via Modbus-RTU, otherwise the setting data can only be read. Default value is ON.

6.12. SCROLL SETTING

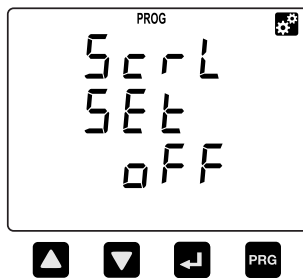

- Scroll in programming mode until "Scrl SEt" is displayed using the UP or the DOWN button.
- This function is to turn ON/OFF scroll mode. If turn on, when the display is idle the meter will shows each window in normal mode base on the scroll delay setting time.
- Press the NEXT button. The "PROG" symbol will blink. Use the UP or DOWN button to toggle "oFF" or "on" symbols.
- Press the NEXT button to confirm the new setting.
- The SAVE window will be prompted. Press the UP or DOWN button to select "YES" or "NO". Press the PROG button to confirm.
- Use the DOWN button to scroll to next setting.
- To exit programming mode, refer Section 6.17.

NOTE:

Scroll setting default value is OFF

6.13. SCROLL DELAY SETTING

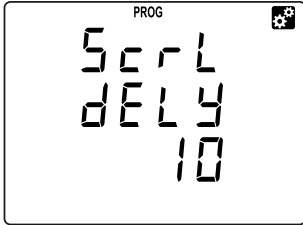

- Scroll in programming mode until "Scrl dELY" is displayed using the UP or the DOWN button.
- This function is to set time interval for scroll window.
- Press the NEXT button. The "PROG" symbol will blink. Use the UP or DOWN button to set 1sec to 10secs interval.
- Press the NEXT button to confirm the new setting.
- The SAVE window will be prompted. Press the UP or DOWN button to select "YES" or "NO". Press the PROG button to confirm.
- Use the DOWN button to scroll to next setting.
- To exit programming mode, refer Section 6.17.

NOTE:

Scroll delay time default value is 10 seconds.

6.14. RESET HOUR @ OPERATION HOUR-ON REGISTER



@

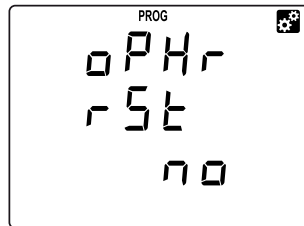

- Scroll in programming mode until "Hron rSt" @ "oPHr rSt" is displayed using the UP or the DOWN button.
- This function is to clear hour @ operation hour-on register.
- Press the NEXT button. The "PROG" symbol will blink. Use the UP or DOWN button to toggle "yES" or "no" symbols.
- To abort clearing hour @ operation hour-on register, select "no". To clear hour @ operation hour-on register select "yES".
- Press the NEXT button to confirm the new setting.
- The rSt data window will be prompted. Press the UP or DOWN button to select "YES" or "NO". Press the PROG button to confirm.
- Use the DOWN button to scroll to next setting.
- To exit programming mode, refer Section 6.17.

6.15. BACKLIGHT SETTING

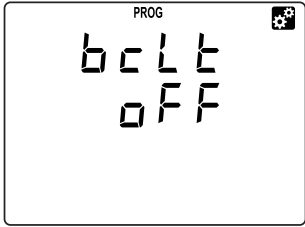

- Scroll in programming mode until "bcLt" is displayed using the UP or the DOWN button.
- This function is to turn off backlight after 5 minutes idle.
- Press the NEXT button. The "PROG" symbol will blink. Use the UP or DOWN button to toggle "oFF" or "on" symbols.
- Press the NEXT button to confirm the new setting.
- The SAVE window will be prompted. Press the UP or DOWN button to select "YES" or "NO". Press the PROG button to confirm.
- Use the DOWN button to scroll to next setting.
- To exit programming mode, refer Section 6.17.

NOTE:

Backlight setting default value is oFF

6.16. SOFTWARE VERSION

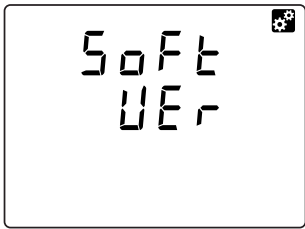

- Scroll in programming mode until "SoFt VE" is displayed using the UP or the DOWN button.
- This window will display the current firmware version of the device.
- Use the DOWN button to scroll to next setting.
- To exit programming mode, refer Section 6.17.

6.17. EXIT FROM PROGRAMMING MODE

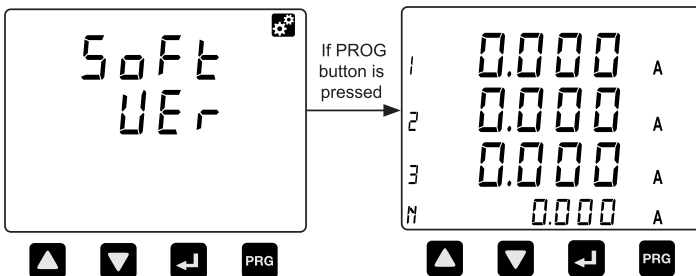

- Use the PROG button exit from programming mode window. The line current window will be displayed.

6.18. SETUP THE PASSWORD

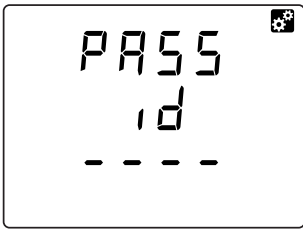

- a. Press the NEXT and PROG buttons simultaneously until the password ID request window is displayed. Key in the current password. Refer to Section 6.1 on how to do this.

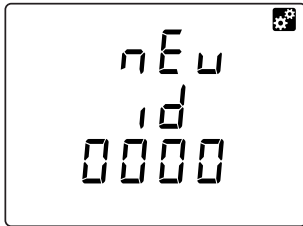

- b. After pressing the PROG button, the "nEW id" window will be displayed. At this stage, the user needs to key in the new password. Use the UP or DOWN button to change the digit value and the NEXT button to shift to next digit. Once confirmed, press the PROG button.

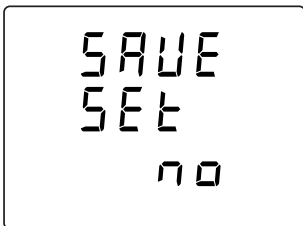

- c. Next, the "SAVE SET" will be displayed. Use the UP or DOWN buttons to toggle the "yES" and "no" symbols to save the new password. Once confirmed, press the PROG button and the meter will return to normal display mode.

7. Specification

Table 4: Specification

Electrical Characteristic	
System	3P3W & 3P4W
Current	
Display	Three phase current & neutral(selectable)
CT Primary	1-2999A / 5-9999A
CT Secondary	1A / 5A
Accuracy	0.5% (from 1A to 6A secondary)
Sustained overload	6A
Voltage measurement	
PT Primary	100-33kV
PT Secondary	no PT, 100-250V
Secondary Phase Voltage	20~300VAC
Accuracy	0.5%
Power (kW,kVAR,kVA) measurement	
Display	each phase & total
Accuracy	1%
Power factor measurement	
Display	each phase & total
Accuracy	1%
Frequency measurement	
Range	45 ~ 65 Hz
Accuracy	0.5%
Energy measurement	
Active	IEC62053-21:Class 1
Reactive	IEC62053-23:Class 2
Demand measurement	
Demand interval	60 to 1800 seconds
Demand sub-interval	1 to 120

Table 4: Specification (cont)

Communication	
Hardware Interface	Isolated RS485
Protocol	Modbus-RTU
ID	1 to 254
Baudrate	4800, 9600, 19200, 38400
Parity	None (Stop Bit 1 and 2), even, odd
Operating Condition	
Auxiliary Supply	90~300VAC or 100~300VDC
Operating Temperature	-10 C ~ +55 C
Storage Temperature	-20 C ~ +70 C
Operating time (on hour)	Up to 9999 days, 23 hours, 59 minutes.
Mechanical Characteristic	
Dimension	
Case	L96mm x W96mm x H87.5mm
Mounting type	Panel
LCD view area	76mm x 56.5mm
Weight	390g
Electromagnetic Compatibility (EMC)	
Part 6-2: Generic Standards IEC61000-6-2	Immunity for industrial environments
Part 6-4: Generic Standards IEC61000-6-4	Emission standard for industrial environments

8. Modbus Data Register

8.1 Data Type

By default, the data format in each register is unsigned 16-bit word. Shorter data may be encoded in the unsigned 8-bit byte format whereas longer data may be encoded either in the unsigned 32-bit double word format, signed 32-bit integer format or signed 64-bit long integer format. Two's complement is used to represent signed numbers. The nomenclature used in this manual is shown in Table 5.

Table 5: Data length nomenclature

Data Length	Unsigned	Signed
4-bit	nibble	-
8-bit	byte	-
16-bit	word	short
32-bit	dword	int
64-bit	qword	long

For data with length shorter than 16 bits, the upper unused bits, nibbles or bytes can be ignored. In cases where multiple registers are required, the big endian convention shall apply unless otherwise specified.

8.2 List Register

Tables 6, 7 and 8 shows the read only variables (function code 0x03 or 0x04) for device & communication info, system status errors, operations, power factor and harmonics data respectively whereas Table 9 shows the read and write variables (function codes 0x03, 0x04 or 0x06) for the settings data.

Table 6: Device and communication register

Read Only (Function 0x03 or 0x04)		
0	Reserved	
1-3	Device Type	
4-5	Version	

Table 7: System status error register

Read Only (Function 0x03 or 0x04)				
Register	Description	Type	Range	
300	System Status Error flag	word	Error flag * Bit 15 = Voltage Sequence Error Bit 14 = Current Sequence Error Bit 10 = L3 Phase Loss Bit 9 = L2 Phase Loss Bit 8 = L1 Phase Loss Bit 7 = L3 Invalid Power Factor Bit 6 = L2 Invalid Power Factor Bit 5 = L1 Invalid Power Factor	

*if error occurred, the bit is set to 1, else bit is 0.

Table 8: Operation data registers

Read Only (Function 0x03 or 0x04)				
Register	Description	Type	Min. Unit	Range
4000-4001	Negative Real Energy	dword	1kWh	0 ~ 1000000M
4002-4003	Positive Real Energy	dword	1kWh	0 ~ 1000000M
4004-4005	Reserved			
4006-4007	Apparent Energy	dword	1kVAh	0 ~ 1000000M
4008-4009	Negative Reactive Energy	dword	1kVArh	0 ~ 1000000M
4010-4011	Positive Reactive Energy	dword	1kVArh	0 ~ 1000000M
4012-4013	Total Real Power	int	1W	-999.9M ~ 999.9M
4014-4015	Total Apparent Power	dword	1VA	0 ~ 999.9M
4016-4017	Total Reactive Power	int	1VAR	-999.9M ~ 999.9M
4018	Total Power Factor	word	0.001	-1.000 ~ 1.000
4019	Frequency	word	0.01Hz	45.00 ~ 65.00
4020-4021	Instantaneous Current L1	dword	0.001A	0 ~ 999.9kA
4022-4023	Instantaneous Current L2	dword	0.001A	0 ~ 999.9kA
4024-4025	Instantaneous Current L3	dword	0.001A	0 ~ 999.9kA
4026-4027	Instantaneous Current Ln	dword	0.001A	0 ~ 999.9kA
4028-4029	Voltage Phase L12	dword	0.1V	0 ~ 999.9kV
4030-4031	Voltage Phase L23	dword	0.1V	0 ~ 999.9kV
4032-4033	Voltage Phase L31	dword	0.1V	0 ~ 999.9kV

Table 8: Operation data registers

Read Only (Function 0x03 or 0x04)				
Register	Description	Type	Min. Unit	Range
4034-4035	Voltage Phase L1	dword	0.1V	0 ~ 999.9kV
4036-4037	Voltage Phase L2	dword	0.1V	0 ~ 999.9kV
4038-4039	Voltage Phase L3	dword	0.1V	0 ~ 999.9kV
4040-4041	Real Power L1	int	1W	-999.9M ~ 999.9M
4042-4043	Real Power L2	int	1W	-999.9M ~ 999.9M
4044-4045	Real Power L3	int	1W	-999.9M ~ 999.9M
4046-4047	Apparent Power L1	dword	1VA	0 ~ 999.9M
4048-4049	Apparent Power L2	dword	1VA	0 ~ 999.9M
4050-4051	Apparent Power L3	dword	1VA	0 ~ 999.9M
4052-4053	Reactive Power L1	int	1VAR	-999.9M ~ 999.9M
4054-4055	Reactive Power L2	int	1VAR	-999.9M ~ 999.9M
4056-4057	Reactive Power L3	int	1VAR	-999.9M ~ 999.9M
4058-4059	Total Demand Reactive Power	int	1VAR	-999.9M ~ 999.9M
4060-4061	Max.Total Demand Reactive Power	int	1VAR	-999.9M ~ 999.9M
4062-4063	Reserved			
4064-4065	Total Demand Real Power	int	1W	-999.9M ~ 999.9M
4066-4067	Max. Total Demand Real Power	int	1W	-999.9M ~ 999.9M
4068-4069	Reserved			
4070-4071	Total Demand Apparent Power	dword	1VA	0 ~ 999.9M
4072-4073	Max. Total Demand Apparent Power	dword	1VA	0 ~ 999.9M
4074-4075	Reserved			
4076	Displacement Power Factor L1	word	0.001	-1.000 ~ 1.000
4077	Displacement PF sign L1	word	-	0=Resistive; 1=ind; 2=cap
4078	Displacement Power Factor L2	word	0.001	-1.000 ~ 1.000
4079	Displacement PF sign L2	word	-	0=Resistive; 1=ind; 2=cap

NOTE: If the display shows “E”, it denotes the value has exceed the range.

Table 8: Operation data register (cont)

Read Only (Function 0x03 or 0x04)				
Register	Description	Type	Min. Unit	Range
4080	Displacement Power Factor L3	word	0.001	-1.000 ~ 1.000
4081	Displacement PF sign L3	word	-	0=Resistive; 1=ind; 2=cap
4082	THD Current L1	word	0.1%	0 ~ 1000
4083	THD Current L2	word	0.1%	0 ~ 1000
4084	THD Current L3	word	0.1%	0 ~ 1000
4085	THD Voltage L1	word	0.1%	0 ~ 1000
4086	THD Voltage L2	word	0.1%	0 ~ 1000
4087	THD Voltage L3	word	0.1%	0 ~ 1000
4088	Energy Full Flag	word		Energy flag * bit 7 to 5 = reserved bit 4 = (-)kVARh bit 3 = (-) kWh bit 2 = kVAh bit 1 = (+)kVARh bit 0 = (+)kWh
4089	Power Factor L1	word	0.001	-1.000 ~ 1.000
4090	Sign Power Factor L1	word	-	0=Resistive; 1=ind; 2=cap
4091	Power Factor L2	word	0.001	-1.000 ~ 1.000
4092	Sign Power Factor L2	word	-	0=Resistive; 1=ind; 2=cap
4093	Power Factor L3	word	0.001	-1.000 ~ 1.000
4094	Sign Power Factor L3	word	-	0=Resistive; 1=ind; 2=cap
4095	Sign Total Power Factor	word	-	0=Resistive; 1=ind; 2=cap
4096- 4097	Current L1 Max.	dword	0.001A	0 ~ 999.9kA
4098-4099	Reserved			
4100- 4101	Current L2 Max.	dword	0.001A	0 ~ 999.9kA
4102-4103	Reserved			

*if the energy is full, the bit is set to 1, else bit is 0.

NOTE: If the display shows “E”, it denotes the value has exceed the range.

Table 8: Operation data register (cont)

Read Only (Function 0x03 or 0x04)				
Register	Description	Type	Min. Unit	Range
4104- 4105	Current L3 Max.	dword	0.001A	0 ~ 999.9kA
4106-4107	Reserved			
4108- 4109	Current Ln Max.	dword	0.001A	0 ~ 999.9kA
4110-4111	Reserved			
4112- 4113	Voltage L1 Max.	dword	0.1V	0 ~ 999.9kV
4114-4115	Reserved			
4116- 4117	Voltage L2 Max.	dword	0.1V	0 ~ 999.9kV
4118-4119	Reserved			
4120- 4121	Voltage L3 Max.	dword	0.1V	0 ~ 999.9kV
4122-4123	Reserved			
4124- 4125	Voltage L12 Max.	dword	0.1V	0 ~ 999.9kV
4126-4127	Reserved			
4128- 4129	Voltage L23 Max.	dword	0.1V	0 ~ 999.9kV
4130-4131	Reserved			
4132-4133	Voltage L31 Max.	dword	0.1V	0 ~ 999.9kV
4134-4135	Reserved			
4136- 4137	Total Positive Real Power Max.	int	1W	0 ~ 999.9M
4138-4139	Reserved			
4140- 4141	Total Positive Apparent Power Max.	dword	1VA	0 ~ 999.9M
4142-4143	Reserved			
4144- 4145	Total Positive Reactive Power Max.	int	1VAR	0 ~ 999.9M
4146-4147	Reserved			
4148- 4149	Max. Positive Real Power L1	int	1W	0 ~ 999.9M
4150-4151	Reserved			
4152- 4153	Max. Positive Real Power L2	int	1W	0 ~ 999.9M
4154-4155	Reserved			

NOTE: If the display shows “E”, it denotes the value has exceed the range.

Table 8: Operation data register (cont)

Read Only (Function 0x03 or 0x04)				
Register	Description	Type	Min. Unit	Range
4156- 4157	Max. Positive Real Power L3	int	1W	0 ~ 999.9M
4158-4159	Reserved			
4160- 4161	Max. Apparent Power L1	dword	1VA	0 ~ 999.9M
4162-4163	Reserved			
4164- 4165	Max. Apparent Power L2	dword	1VA	0 ~ 999.9M
4166-4167	Reserved			
4168- 4169	Max. Apparent Power L3	dword	1VA	0 ~ 999.9M
4170-4171	Reserved			
4172- 4173	Max. Positive Reactive Power L1	int	1VAR	0 ~ 999.9M
4174-4175	Reserved			
4176- 4177	Max. Positive Reactive Power L2	int	1VAR	0 ~ 999.9M
4178-4179	Reserved			
4180- 4181	Max. Positive Reactive Power L3	int	1VAR	0 ~ 999.9M
4182-4183	Reserved			
4184- 4185	Current L1 Min.	dword	0.001A	0 ~ 999.9kA
4186-4187	Reserved			
4188- 4189	Current L2 Min.	dword	0.001A	0 ~ 999.9kA
4190-4191	Reserved			
4192- 4193	Current L3 Min.	dword	0.001A	0 ~ 999.9kA
4194-4195	Reserved			
4196- 4197	Current Ln Min.	dword	0.001A	0 ~ 999.9kV
4198-4199	Reserved			
4200- 4201	Voltage L1 Min.	dword	0.1V	0 ~ 999.9kV

NOTE: If the display shows “E”, it denotes the value has exceed the range.

Table 8: Operation data register (cont)

Read Only (Function 0x03 or 0x04)				
Register	Description	Type	Min. Unit	Range
4202-4203	Reserved			
4204- 4205	Voltage L2 Min.	dword	0.1V	0 ~ 999.9kV
4206-4207	Reserved			
4208- 4209	Voltage L3 Min.	dword	0.1V	0 ~ 999.9kV
4210-4211	Reserved			
4212- 4213	Voltage L12 Min.	dword	0.1V	0 ~ 999.9kV
4214-4215	Reserved			
4216- 4217	Voltage L23 Min.	dword	0.1V	0 ~ 999.9kV
4218-4219	Reserved			
4220-4221	Voltage L31 Min.	dword	0.1V	0 ~ 999.9kV
4222-4223	Reserved			
4224-4225	Total Positive Real Power Min.	int	1W	0 ~ 999.9M
4226-4227	Reserved			
4228-4229	Total Apparent Power Min.	dword	1VA	0 ~ 999.9M
4230-4231	Reserved			
4232- 4233	Total Positive Reactive Power Min.	int	1VAR	0 ~ 999.9M
4234-4235	Reserved			
4236-4237	Min. Positive Real Power L1	int	1W	0 ~ 999.9M
4238-4239	Reserved			
4240-4241	Min. Positive Real Power L2	int	1W	0 ~ 999.9M
4242-4243	Reserved			
4244-4245	Min. Positive Real Power L3	int	1W	0 ~ 999.9M
4246-4247	Reserved			

NOTE: If the display shows “E”, it denotes the value has exceed the range.

Table 8: Operation data register (cont)

Read Only (Function 0x03 or 0x04)				
Register	Description	Type	Min. Unit	Range
4248-4249	Apparent Power Min. L1	dword	1VA	0 ~ 999.9M
4250-4251	Reserved			
4252-4253	Apparent Power Min. L2	dword	1VA	0 ~ 999.9M
4254-4255	Reserved			
4256-4257	Apparent Power Min. L3	dword	1VA	0 ~ 999.9M
4258-4259	Reserved			
4260-4261	Min. Positive Reactive Power L1	int	1VAR	0 ~ 999.9M
4262-4263	Reserved			
4264-4265	Min. Positive Reactive Power L2	int	1VAR	0 ~ 999.9M
4266-4267	Reserved			
4268-4269	Min. Positive Reactive Power L3	int	1VAR	0 ~ 999.9M
4270-4271	Reserved			
4272-4273	Total Negative Real Power Max.	int	1W	0 ~ 999.9M
4274-4275	Reserved			
4276-4277	Max. Negative Real Power L1	int	1W	0 ~ 999.9M
4278-4279	Reserved			
4280-4281	Max. Negative Real Power L2	int	1W	0 ~ 999.9M
4282-4283	Reserved			
4284-4285	Max Negative Real Power L3	int	1W	0 ~ 999.9M
4286-4287	Reserved			
4288-4289	Total Negative Real Power Min.	int	1W	0 ~ 999.9M
4290-4291	Reserved			
4292-4293	Min. Negative Real Power L1	int	1W	0 ~ 999.9M
4294-4295	Reserved			

NOTE: If the display shows “E”, it denotes the value has exceed the range.

Table 8: Operation data register (cont)

Read Only (Function 0x03 or 0x04)				
Register	Description	Type	Min. Unit	Range
4296-4297	Min. Negative Real Power L2	int	1W	0 ~ 999.9M
4298-4299	Reserved			
4300-4301	Min. Negative Real Power L3	int	1W	0 ~ 999.9M
4302-4303	Reserved			
4304-4305	Total Negative Reactive Power Max.	int	1VAR	0 ~ 999.9M
4306-4307	Reserved			
4308-4309	Max. Negative Reactive Power L1	int	1VAR	0 ~ 999.9M
4310-4311	Reserved			
4312-4313	Max. Negative Reactive Power L2	int	1VAR	0 ~ 999.9M
4314-4315	Reserved			
4316-4317	Max. Negative Reactive Power L3	int	1VAR	0 ~ 999.9M
4318-4319	Reserved			
4320-4321	Total Negative Reactive Power Min.	int	1VAR	0 ~ 999.9M
4322-4323	Reserved			
4324-4325	Min. Negative Reactive Power L1	int	1VAR	0 ~ 999.9M
4326-4327	Reserved			
4328-4329	Min. Negative Reactive Power L2	int	1VAR	0 ~ 999.9M
4330-4331	Reserved			
4332-4333	Min. Negative Reactive Power L3	int	1VAR	0 ~ 999.9M
4334-4335	Reserved			

NOTE: If the display shows “E”, it denotes the value has exceed the range.

Table 8: Operation data register (cont)

Read Only (Function 0x03 or 0x04)				
Register	Description	Type	Min. Unit	Range
4336-4337	Positive Real Energy L1	dword	1kWh	0 ~ 1000000M
4338-4339	Positive Real Energy L2	dword	1kWh	0 ~ 1000000M
4340-4341	Positive Real Energy L3	dword	1kWh	0 ~ 1000000M
4342-4343	Positive Reactive Energy L1	dword	1kVARh	0 ~ 1000000M
4344-4345	Positive Reactive Energy L2	dword	1kVARh	0 ~ 1000000M
4346-4347	Positive Reactive Energy L3	dword	1kVARh	0 ~ 1000000M
4348-4349	Negative Real Energy L1	dword	1kWh	-1000000M ~ 0
4350-4351	Negative Real Energy L2	dword	1kWh	-1000000M ~ 0
4352-4353	Negative Real Energy L3	dword	1kWh	-1000000M ~ 0
4354-4355	Negative Reactive Energy L1	dword	1kVARh	-1000000M ~ 0
4356-4357	Negative Reactive Energy L2	dword	1kVARh	-1000000M ~ 0
4358-4359	Negative Reactive Energy L3	dword	1kVARh	-1000000M ~ 0
4360-4361	Apparent Energy L1	dword	1kVAh	0 ~ 1000000M
4362-4363	Apparent Energy L2	dword	1kVAh	0 ~ 1000000M
4364-4365	Apparent Energy L3	dword	1kVAh	0 ~ 1000000M
4500	1st Harmonic: Current L1	word	0.1%	0 ~ 1000
4501	2nd Harmonic: Current L1	word	0.1%	0 ~ 1000
4502	3rd Harmonic: Current L1	word	0.1%	0 ~ 1000
4503	4th Harmonic: Current L1	word	0.1%	0 ~ 1000
4504	5th Harmonic: Current L1	word	0.1%	0 ~ 1000
4505	6th Harmonic: Current L1	word	0.1%	0 ~ 1000
4506	7th Harmonic: Current L1	word	0.1%	0 ~ 1000
4507	8th Harmonic: Current L1	word	0.1%	0 ~ 1000
4508	9th Harmonic: Current L1	word	0.1%	0 ~ 1000

NOTE: The above register values (register 4336-4691) are only shown in MODBUS

Table 8: Operation data register (cont)

Read Only (Function 0x03 or 0x04)				
Register	Description	Type	Min. Unit	Range
4509	10th Harmonic: Current L1	word	0.1%	0 ~ 1000
4510	11th Harmonic: Current L1	word	0.1%	0 ~ 1000
4511	12th Harmonic: Current L1	word	0.1%	0 ~ 1000
4512	13th Harmonic: Current L1	word	0.1%	0 ~ 1000
4513	14th Harmonic: Current L1	word	0.1%	0 ~ 1000
4514	15th Harmonic: Current L1	word	0.1%	0 ~ 1000
4515	16th Harmonic: Current L1	word	0.1%	0 ~ 1000
4516	17th Harmonic: Current L1	word	0.1%	0 ~ 1000
4517	18th Harmonic: Current L1	word	0.1%	0 ~ 1000
4518	19th Harmonic: Current L1	word	0.1%	0 ~ 1000
4519	20th Harmonic: Current L1	word	0.1%	0 ~ 1000
4520	21st Harmonic: Current L1	word	0.1%	0 ~ 1000
4521	22nd Harmonic: Current L1	word	0.1%	0 ~ 1000
4522	23rd Harmonic: Current L1	word	0.1%	0 ~ 1000
4523	24th Harmonic: Current L1	word	0.1%	0 ~ 1000
4524	25th Harmonic: Current L1	word	0.1%	0 ~ 1000
4525	26th Harmonic: Current L1	word	0.1%	0 ~ 1000
4526	27th Harmonic: Current L1	word	0.1%	0 ~ 1000
4527	28th Harmonic: Current L1	word	0.1%	0 ~ 1000
4528	29th Harmonic: Current L1	word	0.1%	0 ~ 1000
4529	30th Harmonic: Current L1	word	0.1%	0 ~ 1000
4530	31st Harmonic: Current L1	word	0.1%	0 ~ 1000
4531	32nd Harmonic: Current L1	word	0.1%	0 ~ 1000
4532	1st Harmonic: Current L2	word	0.1%	0 ~ 1000

NOTE: The above register values (register 4336-4691) are only shown in MODBUS

Table 8: Operation data register (cont)

Read Only (Function 0x03 or 0x04)				
Register	Description	Type	Min. Unit	Range
4533	2nd Harmonic: Current L2	word	0.1%	0 ~ 1000
4534	3rd Harmonic: Current L2	word	0.1%	0 ~ 1000
4535	4th Harmonic: Current L2	word	0.1%	0 ~ 1000
4536	5th Harmonic: Current L2	word	0.1%	0 ~ 1000
4537	6th Harmonic: Current L2	word	0.1%	0 ~ 1000
4538	7th Harmonic: Current L2	word	0.1%	0 ~ 1000
4539	8th Harmonic: Current L2	word	0.1%	0 ~ 1000
4540	9th Harmonic: Current L2	word	0.1%	0 ~ 1000
4541	10th Harmonic: Current L2	word	0.1%	0 ~ 1000
4542	11th Harmonic: Current L2	word	0.1%	0 ~ 1000
4543	12th Harmonic: Current L2	word	0.1%	0 ~ 1000
4544	13th Harmonic: Current L2	word	0.1%	0 ~ 1000
4545	14th Harmonic: Current L2	word	0.1%	0 ~ 1000
4546	15th Harmonic: Current L2	word	0.1%	0 ~ 1000
4547	16th Harmonic: Current L2	word	0.1%	0 ~ 1000
4548	17th Harmonic: Current L2	word	0.1%	0 ~ 1000
4549	18th Harmonic: Current L2	word	0.1%	0 ~ 1000
4550	19th Harmonic: Current L2	word	0.1%	0 ~ 1000
4551	20th Harmonic: Current L2	word	0.1%	0 ~ 1000
4552	21st Harmonic: Current L2	word	0.1%	0 ~ 1000
4553	22nd Harmonic: Current L2	word	0.1%	0 ~ 1000
4554	23rd Harmonic: Current L2	word	0.1%	0 ~ 1000
4555	24th Harmonic: Current L2	word	0.1%	0 ~ 1000
4556	25th Harmonic: Current L2	word	0.1%	0 ~ 1000

NOTE: The above register values (register 4336-4691) are only shown in MODBUS

Table 8: Operation data register (cont)

Read Only (Function 0x03 or 0x04)				
Register	Description	Type	Min. Unit	Range
4557	26th Harmonic: Current L2	word	0.1%	0 ~ 1000
4558	27th Harmonic: Current L2	word	0.1%	0 ~ 1000
4559	28th Harmonic: Current L2	word	0.1%	0 ~ 1000
4560	29th Harmonic: Current L2	word	0.1%	0 ~ 1000
4561	30th Harmonic: Current L2	word	0.1%	0 ~ 1000
4562	31st Harmonic: Current L2	word	0.1%	0 ~ 1000
4563	32nd Harmonic: Current L2	word	0.1%	0 ~ 1000
4564	1st Harmonic: Current L3	word	0.1%	0 ~ 1000
4565	2nd Harmonic: Current L3	word	0.1%	0 ~ 1000
4566	3rd Harmonic: Current L3	word	0.1%	0 ~ 1000
4567	4th Harmonic: Current L3	word	0.1%	0 ~ 1000
4568	5th Harmonic: Current L3	word	0.1%	0 ~ 1000
4569	6th Harmonic: Current L3	word	0.1%	0 ~ 1000
4570	7th Harmonic: Current L3	word	0.1%	0 ~ 1000
4571	8th Harmonic: Current L3	word	0.1%	0 ~ 1000
4572	9th Harmonic: Current L3	word	0.1%	0 ~ 1000
4573	10th Harmonic: Current L3	word	0.1%	0 ~ 1000
4574	11th Harmonic: Current L3	word	0.1%	0 ~ 1000
4575	12th Harmonic: Current L3	word	0.1%	0 ~ 1000
4576	13th Harmonic: Current L3	word	0.1%	0 ~ 1000
4577	14th Harmonic: Current L3	word	0.1%	0 ~ 1000
4578	15th Harmonic: Current L3	word	0.1%	0 ~ 1000
4579	16th Harmonic: Current L3	word	0.1%	0 ~ 1000
4580	17th Harmonic: Current L3	word	0.1%	0 ~ 1000

NOTE: The above register values (register 4336-4691) are only shown in MODBUS

Table 8: Operation data register (cont)

Read Only (Function 0x03 or 0x04)				
Register	Description	Type	Min. Unit	Range
4581	18th Harmonic: Current L3	word	0.1%	0 ~ 1000
4582	19th Harmonic: Current L3	word	0.1%	0 ~ 1000
4583	20th Harmonic: Current L3	word	0.1%	0 ~ 1000
4584	21st Harmonic: Current L3	word	0.1%	0 ~ 1000
4585	22nd Harmonic: Current L3	word	0.1%	0 ~ 1000
4586	23rd Harmonic: Current L3	word	0.1%	0 ~ 1000
4587	24th Harmonic: Current L3	word	0.1%	0 ~ 1000
4588	25th Harmonic: Current L3	word	0.1%	0 ~ 1000
4589	26th Harmonic: Current L3	word	0.1%	0 ~ 1000
4590	27th Harmonic: Current L3	word	0.1%	0 ~ 1000
4591	28th Harmonic: Current L3	word	0.1%	0 ~ 1000
4592	29th Harmonic: Current L3	word	0.1%	0 ~ 1000
4593	30th Harmonic: Current L3	word	0.1%	0 ~ 1000
4594	31st Harmonic: Current L3	word	0.1%	0 ~ 1000
4595	32nd Harmonic: Current L3	word	0.1%	0 ~ 1000
4596	1st Harmonic: Voltage L1	word	0.1%	0 ~ 1000
4597	2nd Harmonic: Voltage L1	word	0.1%	0 ~ 1000
4598	3rd Harmonic: Voltage L1	word	0.1%	0 ~ 1000
4599	4th Harmonic: Voltage L1	word	0.1%	0 ~ 1000
4600	5th Harmonic: Voltage L1	word	0.1%	0 ~ 1000
4601	6th Harmonic: Voltage L1	word	0.1%	0 ~ 1000
4602	7th Harmonic: Voltage L1	word	0.1%	0 ~ 1000
4603	8th Harmonic: Voltage L1	word	0.1%	0 ~ 1000
4604	9th Harmonic: Voltage L1	word	0.1%	0 ~ 1000

NOTE: The above register values (register 4336-4691) are only shown in MODBUS

Table 8: Operation data register (cont)

Read Only (Function 0x03 or 0x04)				
Register	Description	Type	Min. Unit	Range
4605	10th Harmonic: Voltage L1	word	0.1%	0 ~ 1000
4606	11th Harmonic: Voltage L1	word	0.1%	0 ~ 1000
4607	12th Harmonic: Voltage L1	word	0.1%	0 ~ 1000
4608	13th Harmonic: Voltage L1	word	0.1%	0 ~ 1000
4609	14th Harmonic: Voltage L1	word	0.1%	0 ~ 1000
4610	15th Harmonic: Voltage L1	word	0.1%	0 ~ 1000
4611	16th Harmonic: Voltage L1	word	0.1%	0 ~ 1000
4612	17th Harmonic: Voltage L1	word	0.1%	0 ~ 1000
4613	18th Harmonic: Voltage L1	word	0.1%	0 ~ 1000
4614	19th Harmonic: Voltage L1	word	0.1%	0 ~ 1000
4615	20th Harmonic: Voltage L1	word	0.1%	0 ~ 1000
4616	21st Harmonic: Voltage L1	word	0.1%	0 ~ 1000
4617	22nd Harmonic: Voltage L1	word	0.1%	0 ~ 1000
4618	23rd Harmonic: Voltage L1	word	0.1%	0 ~ 1000
4619	24th Harmonic: Voltage L1	word	0.1%	0 ~ 1000
4620	25th Harmonic: Voltage L1	word	0.1%	0 ~ 1000
4621	26th Harmonic: Voltage L1	word	0.1%	0 ~ 1000
4622	27th Harmonic: Voltage L1	word	0.1%	0 ~ 1000
4623	28th Harmonic: Voltage L1	word	0.1%	0 ~ 1000
4624	29th Harmonic: Voltage L1	word	0.1%	0 ~ 1000
4625	30th Harmonic: Voltage L1	word	0.1%	0 ~ 1000
4626	31st Harmonic: Voltage L1	word	0.1%	0 ~ 1000
4627	32nd Harmonic: Voltage L1	word	0.1%	0 ~ 1000
4628	1st Harmonic: Voltage L2	word	0.1%	0 ~ 1000

NOTE: The above register values (register 4336-4691) are only shown in MODBUS

Table 8: Operation data register (cont)

Read Only (Function 0x03 or 0x04)				
Register	Description	Type	Min. Unit	Range
4629	2nd Harmonic: Voltage L2	word	0.1%	0 ~ 1000
4630	3rd Harmonic: Voltage L2	word	0.1%	0 ~ 1000
4631	4th Harmonic: Voltage L2	word	0.1%	0 ~ 1000
4632	5th Harmonic: Voltage L2	word	0.1%	0 ~ 1000
4633	6th Harmonic: Voltage L2	word	0.1%	0 ~ 1000
4634	7th Harmonic: Voltage L2	word	0.1%	0 ~ 1000
4635	8th Harmonic: Voltage L2	word	0.1%	0 ~ 1000
4636	9th Harmonic: Voltage L2	word	0.1%	0 ~ 1000
4637	10th Harmonic: Voltage L2	word	0.1%	0 ~ 1000
4638	11th Harmonic: Voltage L2	word	0.1%	0 ~ 1000
4639	12th Harmonic: Voltage L2	word	0.1%	0 ~ 1000
4640	13th Harmonic: Voltage L2	word	0.1%	0 ~ 1000
4641	14th Harmonic: Voltage L2	word	0.1%	0 ~ 1000
4642	15th Harmonic: Voltage L2	word	0.1%	0 ~ 1000
4643	16th Harmonic: Voltage L2	word	0.1%	0 ~ 1000
4644	17th Harmonic: Voltage L2	word	0.1%	0 ~ 1000
4645	18th Harmonic: Voltage L2	word	0.1%	0 ~ 1000
4646	19th Harmonic: Voltage L2	word	0.1%	0 ~ 1000
4647	20th Harmonic: Voltage L2	word	0.1%	0 ~ 1000
4648	21st Harmonic: Voltage L2	word	0.1%	0 ~ 1000
4649	22nd Harmonic: Voltage L2	word	0.1%	0 ~ 1000
4650	23rd Harmonic: Voltage L2	word	0.1%	0 ~ 1000
4651	24th Harmonic: Voltage L2	word	0.1%	0 ~ 1000
4652	25th Harmonic: Voltage L2	word	0.1%	0 ~ 1000

NOTE: The above register values (register 4336-4691) are only shown in MODBUS

Table 8: Operation data register (cont)

Read Only (Function 0x03 or 0x04)				
Register	Description	Type	Min. Unit	Range
4653	26th Harmonic: Voltage L2	word	0.1%	0 ~ 1000
4654	27th Harmonic: Voltage L2	word	0.1%	0 ~ 1000
4655	28th Harmonic: Voltage L2	word	0.1%	0 ~ 1000
4656	29th Harmonic: Voltage L2	word	0.1%	0 ~ 1000
4657	30th Harmonic: Voltage L2	word	0.1%	0 ~ 1000
4658	31st Harmonic: Voltage L2	word	0.1%	0 ~ 1000
4659	32nd Harmonic: Voltage L2	word	0.1%	0 ~ 1000
4660	1st Harmonic: Voltage L3	word	0.1%	0 ~ 1000
4661	2nd Harmonic: Voltage L3	word	0.1%	0 ~ 1000
4662	3rd Harmonic: Voltage L3	word	0.1%	0 ~ 1000
4663	4th Harmonic: Voltage L3	word	0.1%	0 ~ 1000
4664	5th Harmonic: Voltage L3	word	0.1%	0 ~ 1000
4665	6th Harmonic: Voltage L3	word	0.1%	0 ~ 1000
4666	7th Harmonic: Voltage L3	word	0.1%	0 ~ 1000
4667	8th Harmonic: Voltage L3	word	0.1%	0 ~ 1000
4668	9th Harmonic: Voltage L3	word	0.1%	0 ~ 1000
4669	10th Harmonic: Voltage L3	word	0.1%	0 ~ 1000
4670	11th Harmonic: Voltage L3	word	0.1%	0 ~ 1000
4671	12th Harmonic: Voltage L3	word	0.1%	0 ~ 1000
4672	13th Harmonic: Voltage L3	word	0.1%	0 ~ 1000
4673	14th Harmonic: Voltage L3	word	0.1%	0 ~ 1000
4674	15th Harmonic: Voltage L3	word	0.1%	0 ~ 1000
4675	16th Harmonic: Voltage L3	word	0.1%	0 ~ 1000
4676	17th Harmonic: Voltage L3	word	0.1%	0 ~ 1000

NOTE: The above register values (register 4336-4691) are only shown in MODBUS

Table 8: Operation data register (cont)

Read Only (Function 0x03 or 0x04)				
Register	Description	Type	Min. Unit	Range
4677	18th Harmonic: Voltage L3	word	0.1%	0 ~ 1000
4678	19th Harmonic: Voltage L3	word	0.1%	0 ~ 1000
4679	20th Harmonic: Voltage L3	word	0.1%	0 ~ 1000
4680	21st Harmonic: Voltage L3	word	0.1%	0 ~ 1000
4681	22nd Harmonic: Voltage L3	word	0.1%	0 ~ 1000
4682	23rd Harmonic: Voltage L3	word	0.1%	0 ~ 1000
4683	24th Harmonic: Voltage L3	word	0.1%	0 ~ 1000
4684	25th Harmonic: Voltage L3	word	0.1%	0 ~ 1000
4685	26th Harmonic: Voltage L3	word	0.1%	0 ~ 1000
4686	27th Harmonic: Voltage L3	word	0.1%	0 ~ 1000
4687	28th Harmonic: Voltage L3	word	0.1%	0 ~ 1000
4688	29th Harmonic: Voltage L3	word	0.1%	0 ~ 1000
4689	30th Harmonic: Voltage L3	word	0.1%	0 ~ 1000
4690	31st Harmonic: Voltage L3	word	0.1%	0 ~ 1000
4691	32nd Harmonic: Voltage L3	word	0.1%	0 ~ 1000

NOTE: The above register values (register 4336-4691) are only shown in MODBUS

Table 9: Setting data register

Read or write (Function 0x03,0x04 or 0x06)		
Register	Description	Range
100	PT ratio primary	100 ~ 33kV
101	PT ratio secondary	no PT ('0'), 100 ~ 250V
102	CT ratio primary	1-2999A / 5-9999A
103	CT ratio secondary *	1A / 5A
104	Interval Demand	60 ~ 1800s
105	Sub-Interval Demand	1 ~ 120
106	System Configuration *	0 = 3P4W 1 = 3P3W
107	Backlight setting	0 = OFF 1 = ON
108	Scroll interval	1 - 10 secs
109	System scroll setting	0 = OFF 1 = ON
110	Neutral setting	0 = OFF 1 = Measured 2 = Calculated
111	Minutes	0 - 59 mins
112	Hours	0 - 23 hrs
113	Days	0 - 9999 days
114	Hour-on reset	1 = YES
115	Max. & Min. Demand reset	1 = YES
116	Max. & Min. parameter reset	1 = YES

* read-only function

* Only available on firmware version A2.12 and above

NOTE:

Register list is based on firmware version A2.00

9. Maintenance and Troubleshooting

The power meter does not contain any user-serviceable parts. If the power meter requires service, please contact your local sales representative. Do not open the power meter. Opening the power meter voids the warranty.

NOTE:

We reserve the right to alter or modify the information contained herein at any time in line with our product development without prior notification. We also reserve the right to discontinue production & delivery of product.

10. Meter Dimension

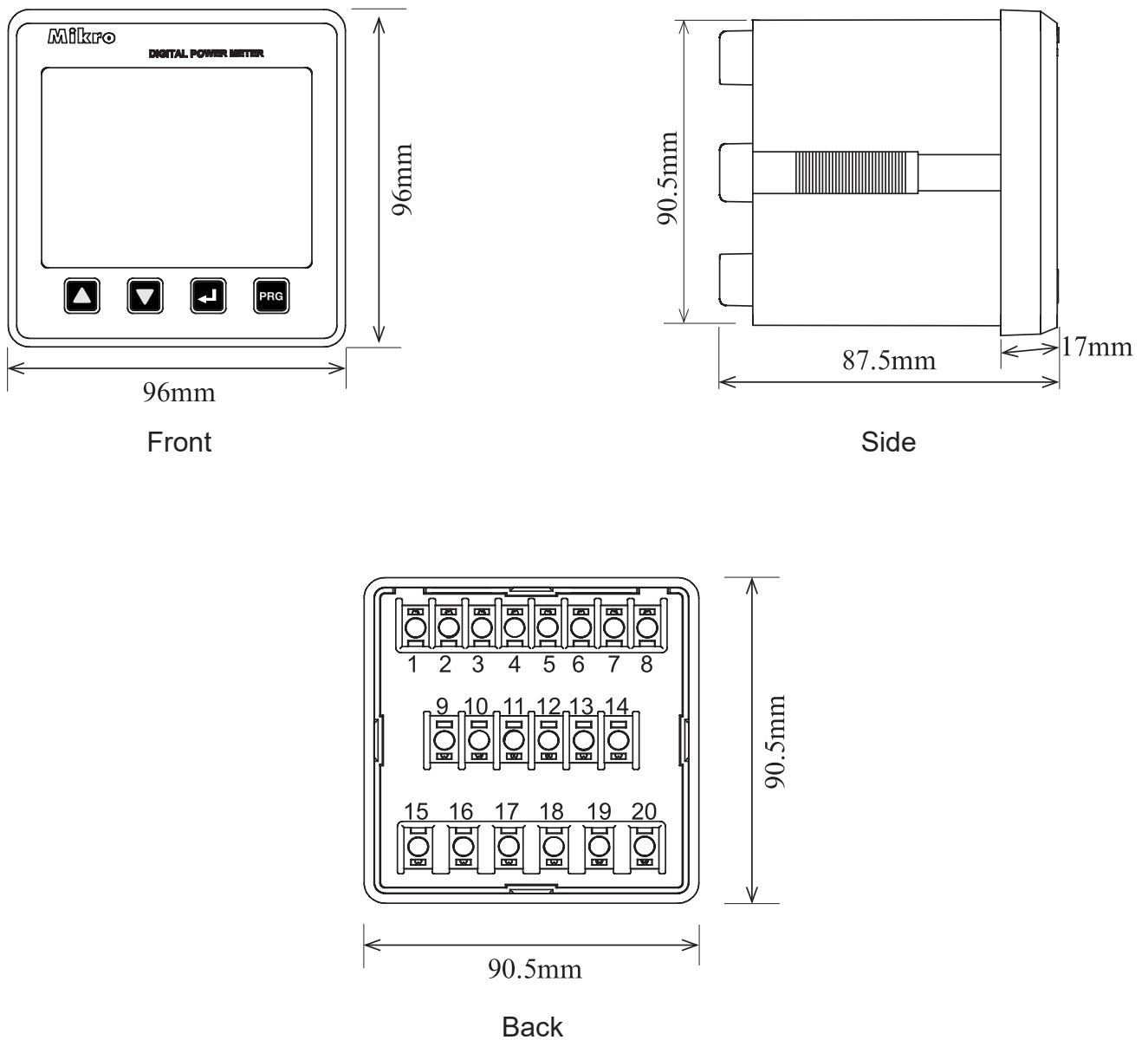

11. Appendix

11.1. DEMAND CALCULATION

Demand parameters are used to show average values over a demand interval. This power meter using sliding block method. The demand value is based on interval divide by sub-interval time. Example is shown below:

SETTING: Interval time = 180 seconds ; sub-interval = 3

Measurement = interval time / sub-interval = 180 / 3
= 60 seconds

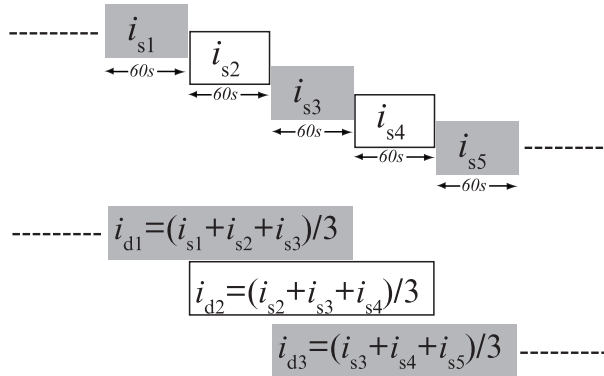

11.2. DATA READ FORMAT FROM MODBUS

a) 4000-4001 : Negative Real Energy

Address 4000		Address 4001	
MSB	LSB	MSB	LSB
0x00	0x01	0x23	0x34

Negative Real Energy = 0x00012334
= 74548 x 1kWh (min value)
= 74548kWh

b) 4012-4013 : Total Real Power; (Signed register)

Address 4012		Address 4013	
MSB	LSB	MSB	LSB
0xFF	0xFB	0x6C	0x20

Total Real Power = 0xFFFFB6C20

If MSB is "1", it is negative value;

Total Real Power = 0xFFFFB6C20 x (-1);
= 0x493E0; 300 000
= 300000 x 1W(min value)
= -300kW

11.3. NEUTRAL CURRENT CALCULATION

The formula for neutral current, I_n is:

$$\sqrt{A^2 + B^2 + C^2 - AB - AC - BC}$$

where;

A: Current Line 1 (A)

B: Current Line 2 (A)

C: Current Line 3 (A)

Example

Given L1 is 3A, L2 is 6A, L3 is 8A;

Substitute into formula;

$$\begin{aligned} &= \sqrt{(3)^2 + (6)^2 + (8)^2 - (2 \times 8) - (3 \times 8) - (6 \times 8)} \\ &= 4.359 \text{ A} \end{aligned}$$

12. Version History

Version	Description
1.0	Released version
1.1	Added Phase Loss Error functionality, MODBUS register 300
1.2	Added stop bit set functionality for none parity communication setting
1.3	Added MODBUS registers 4336 - 4365
1.4	Changed Connection Diagram for MODBUS RTU-485 communication
2.0	Added Phase Harmonics measurement functionality, MODBUS registers 4500 - 4691