

RX96/RX96P Power Factor Controller User Guide

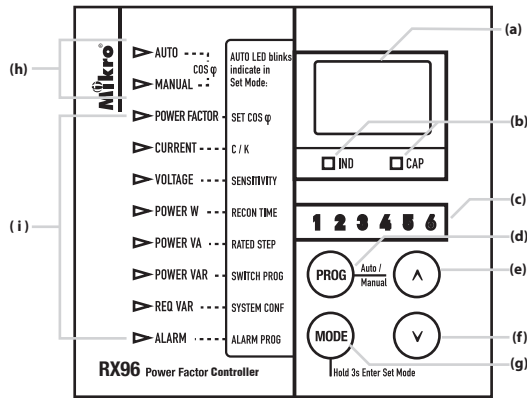

- (a) 3-digit data indication
- (b) Capacitive [CAP] and inductive [IND]
- (c) Step indicator
- (d) PROGRAM key
- (e) MODE/SCROLL key
- (f) DOWN key
- (g) UP key
- (h) AUTO and MANUAL indicators
- (i) Mode indicator

Connection Diagram

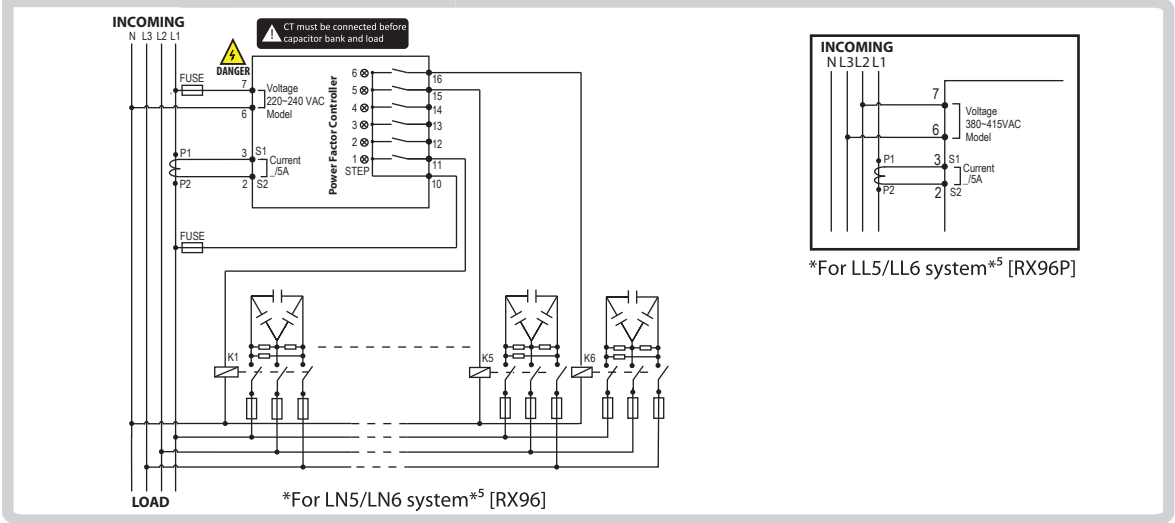

Features

- Microprocessor based intelligent auto switching control.
- Display of Cos ϕ , power factor, voltage, current
- Display power of Active (W), Reactive (var), Apparent (VA) and required var
- No voltage release function
- Automatic C/K and rated step adjustment
- Automatic CT polarity correction
- Programmable sensitivity
- Programmable alarm
- Last step can be used as alarm/fan output
- Alarm of Under/over voltage, under/over compensate and step fault
- Complies with IEC 61000-6-2 standard

Switching Program

OFF	Switching operation is Off, only measurement is operating.
Manual switching (n-A)	Capacitor steps are controlled manually by the "UP" or "DOWN" keys. Steps are switched in a rotational manner based on first-in-first-out basis
Rotational switching (rot)	It is automatically switch in and out the capacitors according to the targeted power factor, sensitivity and reconnection time. Steps are switched in a rotational manner based on first-in-first-out basis
Automatic switching (Aut)	This automatic switching program uses intelligent switching sequence. The step switching sequence is not fixed and the program automatically select the most appropriate steps to switch in or out in order to achieve shortest reaction time with minimum number of steps. For equal ageing of the capacitor and contractors, the program will select the least used step to be switched in if there are two equally rated steps. Under this switching program, the power factor controller automatically detects the CT polarity.
Four-quadrant switching (Fqr)	This switching program is similar to the automatic switching program (AUT) except that this switching program allows the power factor controller to operate correctly under both import power and export power (re-generative) conditions. [Make sure CT polarity is correctly wired when using this program]

Case Dimensions

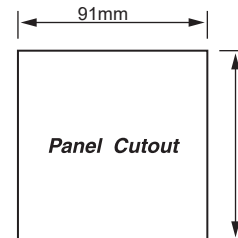
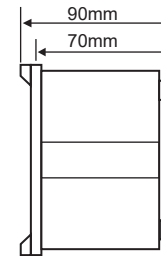
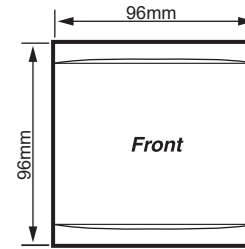

Technical Data

Auxiliary Supply

- Supply Voltage [RX96]..... 220~240 VAC
- [RX96P]..... 380~415VAC
- Operating Limits..... -15% +10%
- VA Rating..... 10VA max
- Frequency..... 50Hz or 60Hz

Current Input

- Rated current, In..... 5A
- Operatings Limits..... 0.05 - 8A
- Rated Frequency..... 50Hz or 60Hz

Output Contacts

- Numbers of Outputs..... 6
- Contact Arrangement..... NO contact type
- Rated Capacity..... 5A 250VAC(Cos ϕ =1)
- Max Current for the Common..... 12A continuous
- Terminals

Control Range

- Power Factor Setting..... 0.8 inductive - 0.8 capacitive
- C/K Setting..... 0.02 - 1.20/ Auto
- Switching Sensitivity..... 5 - 600 s/step
- Reconnection Time for..... 5 - 240 s
- Same Step
- Switching Program..... Off/Automatic/Rotational/Manual/Four-quadrant
- Rated Step Coefficient..... 1 - 16/Fix/Off

Mechanical

- Mounting..... Panel mounting
- Dimension (mm) 96(w) x 96(h) x 70(d)
- Enclosure Protection..... IP54 at the panel
- Approximate Weight..... 0.6kg

Measurement

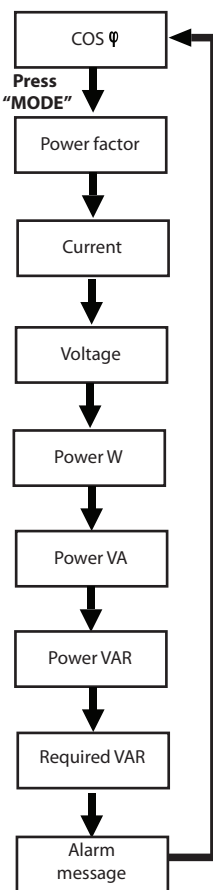

Set Mode

Press and hold "MODE" for 3s to enter Set mode

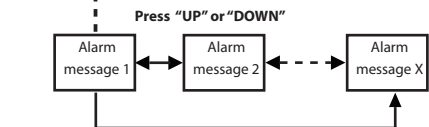
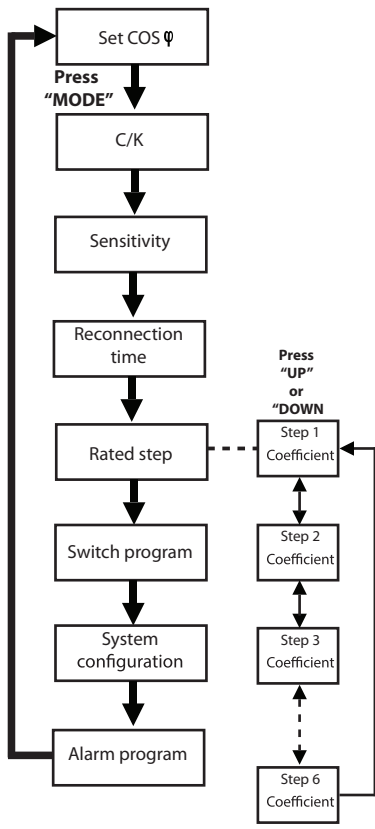

Push Button Operation

Switch between Manual or Auto Mode	Press and hold "PROG" key for 3 seconds on COS φ mode
Programming Lock/Unlock	On COS φ mode, press and hold "PROG" and "DOWN" keys simultaneously until data indication flash "Loc" or "CLr". "Loc" indicates programming locked and "CLr" indicates programming unlock.
Factory default reset	First power off the device, press "UP" and "DOWN" keys simultaneously while turning on the power and holds it for more than 5 seconds until data indication flashes "dEF"
Scroll alarm message	On Alarm mode, press "UP" or "DOWN" key
Scroll step number	On Rated Step mode, press "UP" or "DOWN" key
Step In/Out on manual switch	On COS φ mode, press "UP" to step in or Press "DOWN" to step out

LED Indication

Alarm flashing	Alarm conditions detected
Step number flashing	Waiting reconnection time ready to step in
AUTO LED On	Device is running in auto switch mode
MANUAL LED On	Device is running in manual switch mode

Parameter Settings

Control parameter	Indication LED	Step LED ^{*1}	Setting Range	Default factory setting
Target power factor	SET COS φ		0.80 Ind - 0.80 Cap	0.98Ind
C/K	C/K		0.02 - 1.20/Atc	Atc
Sensitivity	SENSITIVITY		5 - 600 s/step	45 s/step
Reconnection time	RECON TIME		5 - 240 s	30 s
Rated step 1 Rated step 2 ... Rated step 6	RATED STEP	1	001 - 016 / OFF FIS - Fix output ALA ^{*2} - alarm output FAn ^{*3} - fan output	001
Switch program	SWITCH PROG		OFF, n-A, rot, Aut, Fqr	Aut
System configuration	SYSTEM CONF		LL5, LL6, LN5, LN6 ^{*5}	LL5/LN5 ^{*6}
Alarm program ^{*4}	ALARM PROG		000 - FFF _h	FFF _h

*1 - Under normal operation except for rated step display, the step indicator indicate step ON/OFF status
 *2 - Only last output can be configured as alarm output
 *3 - Last output can be configured as fan output, or second last output can be configured as fan output only when last output is configured as alarm output
 *4 - Refers figure 1 for alarm program configuration
 *5 - LL5 is phase to phase 50Hz system, LL6 is phase to phase 60Hz system, LN5 is phase to neutral 50Hz system and LN6 is phase to neutral 60Hz system
 *6 - RX96 is LN5, RX96P is LL5

Alarm Message

Alarm Message	Description	Delay time		Action
		Activate	Deactivate	
Lol	Current lower than 0.05A	10 s	5 s	-
Hil	Current exceed than 5.50A	2 min	1 min	-
LoU	Voltage lower than 295VAC ^{*8}	100 ms	5 s	^{**} All steps disconnected
HiU	Voltage exceed 456 VAC ^{*8}	15 mins	7.5 mins	-
Uco	All capacitors are connected and the power factor lower than COS φ	15 mins	7.5 mins	-
Oco	All capacitors are disconnected and the power factor higher than COS φ	15 mins	7.5 mins	-
ESt	Auto C/K or rated step measurement error. Manual setting required	-	-	-
SFt	Faulty step. Whereas "FLt" will be shown in rate step mode for the step is faulty	-	-	-
UnS	Target cannot be reached due to CK value too high	-	-	-
OUS	Target cannot be reached due to not suitable step size	-	-	-
ECt	Automatic CT polarity detection error	-	-	-

*7 - Automatic switching of steps are prohibited when this alarm occurred
 *8 - For 220 ~ 240 model, LoU is 170VAC & HIU is 264VAC
 REMARKS : When alarm is deactivate (LoU/Lol), the relay will operate as normal

Alarm Program

Digit3 Digit2 Digit1

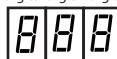

Figure 1: Link element in Hexadecimal value
 0= Disable,
 1= Enable

HEX	Digit3				Digit2				Digit1			
	-	-	OUS	UnS	SFt	ESt	Oco	Uco	HiU	LoU	HiL	Lol
000	-	-	0	0	0	0	0	0	0	0	0	0
001	-	-	0	0	0	0	0	0	0	0	0	1

3FE	-	-	1	1	1	1	1	1	1	1	1	0
3FF	-	-	1	1	1	1	1	1	1	1	1	1

User's setting hexadecimal value	Digit3				Digit2				Digit1			