

# RXD330 Earth Leakage Relay User Guide

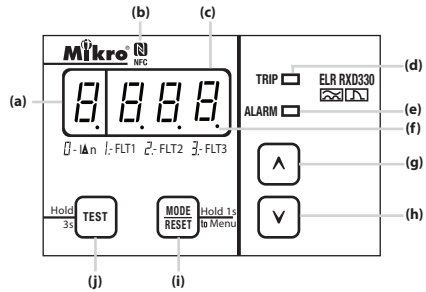

- (a) Function indication
- (b) NFC detection area
- (c) Data indication
- (d) Trip status indicator
- (e) Alarm status indicator
- (f) mA indicator
- (g) Up button
- (h) Down button
- (i) Reset/Mode button
- (j) Test button

## Features

- Built-in NFC for reading and setting parameters through mobile app
- Real-time monitoring of system condition
- Built-in self test and soft recovery watchdog
- Internal relay failure (IRF) alarm for system abnormalities
- Time stamp event record of power failure and setting changes up to 120 events
- Time-stamp record of up to 30 faults and 30 pickups
- Selectable 50 or 60 Hz frequency
- Selectable fundamental or true RMS detection
- Detection of no connection to ZCT
- Protected against nuisance tripping
- Remote reset function
- Incorporated fail-safe feature into trip contact
- Self-reclosing feature

## Case Dimensions

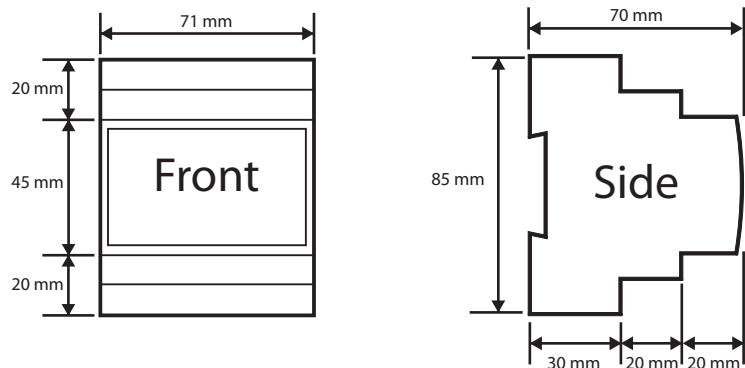

## Typical Application Diagram

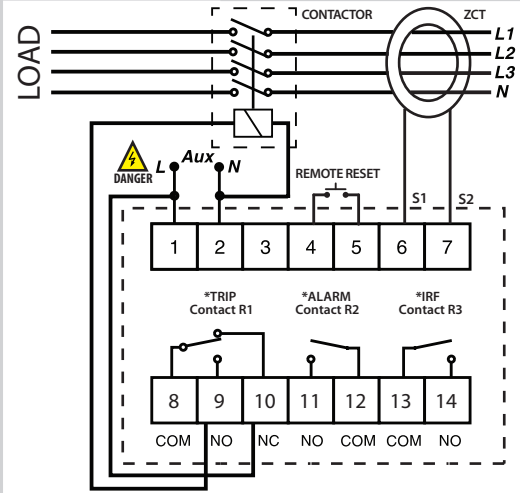

\*All contacts are programmable. Default setting are R1 for trip, R2 for alarm and R3 for IRF.

## NFC Communication



Relay provides convenient NFC communication for users to read parameter values or change settings through an Android phone with NFC feature and Android OS version above 10. The Mikro RX app can be downloaded on the mobile device using one of the following methods:

{Make sure phone NFC function is turned on}

- Scan the QR code or align the mobile phone NFC antenna with the NFC logo on relay front panel. This will take you directly to the app on Google play



## Technical Data

### Auxiliary Supply

Supply Voltage..... 198 ~ 265VAC  
 Supply Frequency..... 50 or 60Hz  
 VA Rating..... 3VA max

### Accuracy

Protection Thresholds..... -15% to 0%  
 Time Delay..... ±3% or 40ms whichever is greater

### Setting Ranges

(i) Earth-leakage Setting  
 IΔn Sensitivity..... 20mA - 30.0A  
 Time Δt..... INST - 10.0s  
 Pre-fault..... 10mA - 24.0A  
 Reset Hysteresis..... 2% - 10%

### (ii) Self Reclosing Setting

Number of Shots..... OFF/1 - 30  
 Dead Time..... 1s - 500s  
 Persistent fault time..... OFF/1s - 500s  
 Reclaim Time..... OFF/1min - 500min  
 Lockout Self Reset Time..... OFF/1h - 200h

### Output Contacts

Rated Voltage..... 250VAC  
 Continuous Carry..... 5A(Cosφ = 1.0)  
 Expected Electrical Life..... 10<sup>8</sup> operations  
 Expected Mechanical Life..... 5 x 10<sup>6</sup> operations

### Environmental Conditions

Temperature..... -10°C to 55°C  
 Humidity..... 5% to 95% non-condensing

### Mechanical

Mounting..... DIN rail mounting  
 Dimension (mm) ..... 71 (w) x 85 (h) x 70 (d)  
 Enclosure Protection..... IP54 at the panel  
 IP20 at the body  
 Approximate Weight..... 0.4kg

### NFC Communication

Operation System..... Android OS  
 Software Version ..... Version 10 and above

### Earth Leakage Protection Class

Type A ☒

### Zero-Phase Current Transformer

To operate with Mikro's ZCT series of current transformer

## System Operation

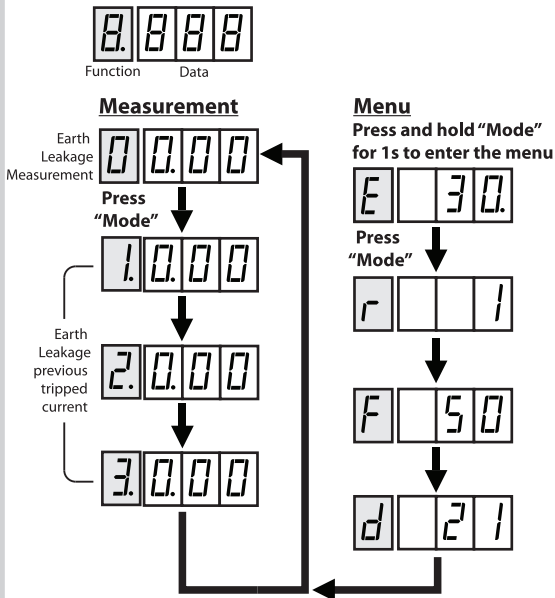

### Push Button Operation

Trip Test	Press and hold "TEST" button for 3 seconds
Trip Reset	Press "RESET" button
Scroll Display	Press "MODE" button
Enter Menu Mode	Press and hold "MODE" button for 1 second
Set/Save Setting	Press "UP" and "DOWN" buttons simultaneously
Adjust Setting	Press "UP" or "DOWN" button
Display Off Mode	Press "RESET" button for 10 seconds to toggle the display off mode. The display will switch off after 6 minutes if no key is pressed.

### Display Indicator

LED		Data Indication	Status
TRIP	ALARM		
0	0	0	No Auxilliary power supply / * IRF trigger
0	0	X	Normal condition, no tripping
1	X	X	Leakage pickup
B	X	Trip value	Leakage tripped
X	1	Ct	ZCT connection fault alarm
X	B	X	Pre-fault alarm
X	B	PLo/Loc	Persistent/ Transient fault lockout alarm

1 = ON 0 = OFF B = Blinking X = don't care

\* Refer to IRF Alert Message table

### Parameter Settings

E	Earth Leakage Setting
1	I <sub>Δn</sub> Sensitivity [DEF=0.30]* <sup>1</sup>
2	Time Δt [DEF=0.50]* <sup>1</sup>
3	Pre-fault [DEF=0.15]
4	Reset Hysteresis [DEF=5]

r	Self Reclosing Setting
1	Number of Shots [DEF=1]
2	Dead Time [DEF=100]
3	Persistent fault time [DEF=OFF]
4	Reclaim Time [DEF=OFF]
5	Lockout Self Reset Time [DEF=OFF]

d	Date and Time Setting
1	Year
2	Month
3	Day
4	Hour
5	Minute
6	Second

F	Functions Setting
1	Frequency [50Hz/60Hz] [DEF=50]
2	Measurement display [Fn=Fundamental, RnS=RMS][DEF=rnS]
3	Output R1 reset type [n-A=Manual, AUt=Auto][DEF=AUt]
4	Output R2 reset type [n-A=Manual, AUt=Auto][DEF=n-A]
5	Output R3 reset type [n-A=Manual, AUt=Auto][DEF=n-A]
6	Fail-safe into trip contact [Yes/No] [DEF=No]
7	* <sup>2</sup> Output R1 function [DEF=TrP]
8	* <sup>2</sup> Output R2 function [DEF=Alr]
9	* <sup>2</sup> Output R3 function [DEF=Irf]
A	Output R1 link element [Refer figure 1][DEF=0F]
b	Output R2 link element [Refer figure 1][DEF=0F]
c	Output R3 link element [Refer figure 1][DEF=0F]
d	NFC remote set [Yes/No] [DEF=No]

[DEF=Default setting]

\*<sup>1</sup> When I<sub>Δn</sub> ≤ 30mA, time Δt is fixed to instantaneous

\*<sup>2</sup> Stc = Safety Contact

Alr = Alarm

Trp = Trip

Irf = Internal Failure

Stc & Irf contact function :

R1, R2 and R3 healthy = energized, fault = de-energized



User's setting	Digit1
User's setting hexadecimal value	

HEX	Digit1			
	PLO	CFA	PFA	LFA
00	0	0	0	0
01	0	0	0	1
02	0	0	1	0
03	0	0	1	1
04	0	1	0	0
05	0	1	0	1
06	0	1	1	0
07	0	1	1	1
08	1	0	0	0
09	1	0	0	1
0A	1	0	1	0
0B	1	0	1	1
0C	1	1	0	0
0D	1	1	0	1
0E	1	1	1	0
0F	1	1	1	1

Figure 1: Link element in Hexadecimal value

0= Off, 1= On

### IRF Alert Message

Function & Data Display	Alert Description
E E P	EEPROM memory malfunction
L o U	Low auxiliary voltage supply
r t C E	Clock IC malfunction
n F C E	NFC IC malfunction
R d c E	Measurement voltage reference unstable

LFA - Leakage Fault alarm

PFA - Pre-fault alarm

CFA - ZCT connection fault alarm

PLO - Persistent fault lockout alarm/Transient fault lockout alarm

## Self Reclosing

Terms	Description
<b>Shots</b>	Nos of self-reclosing operation before the lockout.
<b>Dead time</b>	Trip safe contact is activated by the recloser when the trip safe contact is de-activated due to a leakage fault.
<b>Persistent fault time</b>	Fault detected immediately after the trip safe contact is activated by recloser.
<b>Reclaim time</b>	Time required by the recloser to reset back to reset shot count.
<b>Lockout self reset</b>	Time required to unlock and reset the self-reclosing module during lockout state. The unlock operation is carried out when no operators attended the relay during the lockout state.
<b>Transient fault lockout</b>	When the number of self-reclosing operations matches the number of shots set, further fault trips will perform the lockout
<b>Persistent fault lockout</b>	Relay lockout when the tripping is initiated by the persistent fault.

#### a) Shots, Dead Time and Reclaim Time

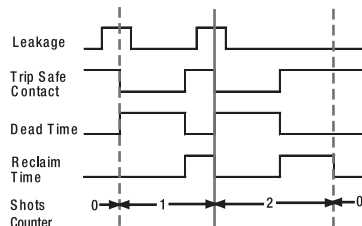

#### b) Persistent fault monitoring time

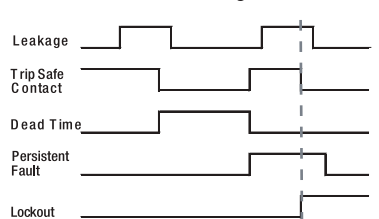

## Setting Ranges Step

### (i) Earth-leakage Setting

I <sub>Δn</sub> Sensitivity .....	20mA - 30.0A (<1.00A step 1mA, <10.0A step 0.01A, <30.0A step 0.1A)
Time Δt .....	INST - 10.0 (<10.0s step 0.01s)
Pre-fault .....	10mA - 24.0A (<1.00A step 1mA, <10.0A step 0.01A, <30.0A step 0.1A)
Reset Hysteresis .....	2% - 10% (<10% step 1%)

### (ii) Self Reclosing Setting

Number of Shots.....	OFF/1 - 30 (OFF, <30 step 1)
Dead Time.....	1s - 500s (<500s step 1s)
Persistent fault time.....	OFF/1s - 500s (OFF, <500s step 1s)
Reclaim Time.....	OFF/1min - 500min (OFF, <500min step 1min)
Lockout Self Reset Time.....	OFF/1h - 200h (OFF, <200h step 1h)