



X80

POWER FACTOR CONTROLLER



FEATURES

- Microprocessor based intelligent auto switching control
- 2 inch, 64 x 128 dot matrix LCD Display with backlighting
- Three phase and single phase detection of reactive power
- 12 (or 8 for 8 step model) output with two additional independent contact for signal alarm output and fan output
- Three phase compensation mode
- 5 different switching program mode
- Automatic detection of C/K and rated step value
- No Voltage Release
- Measurement parameters
 - Active, reactive and apparent power
 - Temperature
 - Phase voltage and phase current
 - Frequency
 - Up till 31st order Harmonics measurement in graphical or table format
 - Power Factor and Displacement Power Factor (Cos φ)
- Various configurable alarm settings
- Alarm linked signal contact
- Programmable fan control
- Modbus-RTU communication
- Fixed step for hybrid switching
- Compatible with Mikrosafe Software

TYPICAL APPLICATION DIAGRAM

X80 Connection diagram for 3 Phase 12 Step model

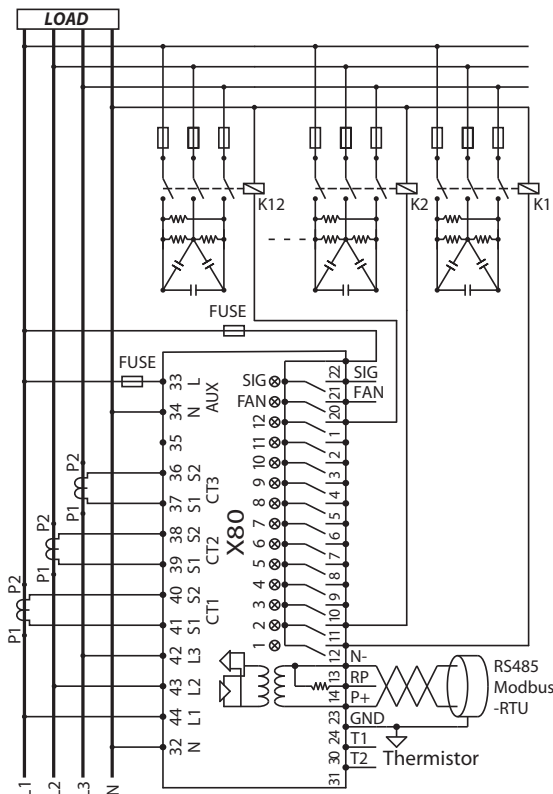

X80 PFR120P3-240-50

X80 Connection diagram for 1 Phase 12 Step model

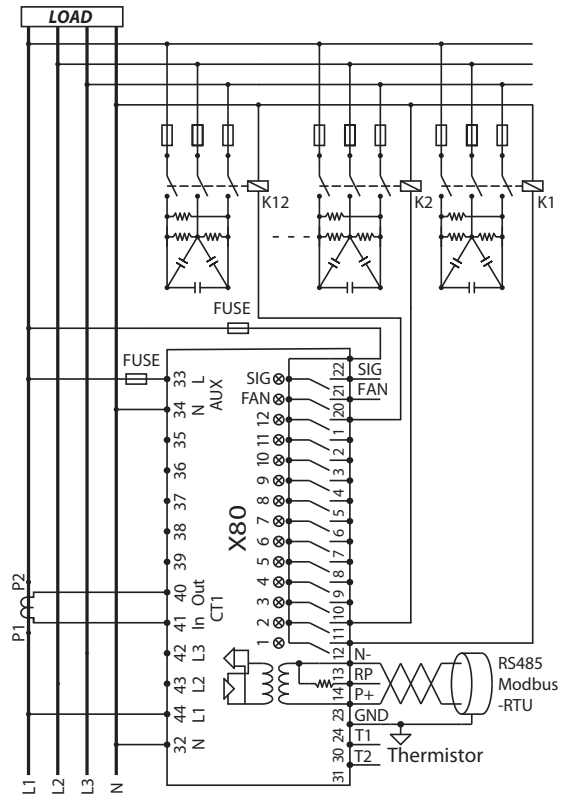

PFRLCD120P1-240-50

CASE DIMENSION

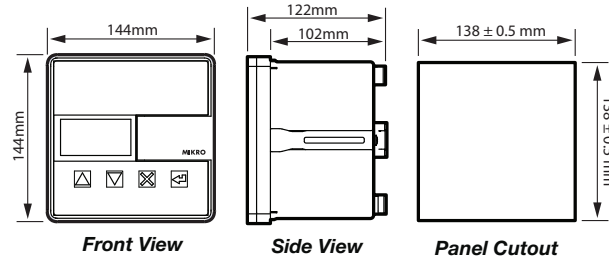

TECHNICAL DATA

CURRENT INPUT (EACH PHASE)

Nominal current	: 5 A
Operating limits	: 0.01 - 10 A
Rated frequency	: 50 Hz

VOLTAGE INPUT (EACH PHASE with respect to neutral)

Nominal voltage	: 230V AC
Operating limits	: 0 - 277 V L-N
Consumption	: 0.05 VA
Rated frequency	: 50 Hz
Category	: III

THERMISTOR INPUT

Thermistor temperature range	: 0 - 100 °C
------------------------------	--------------

AUXILIARY

Auxiliary Input voltage range	: 85 - 265V AC
Consumption	: 10VA max
Rated frequency	: 50 Hz

OUTPUT CONTACTS

Number of outputs	: 14 (model dependent)
Contact arrangement	: NO contact type
Contact rating	: 5A
Expected electrical life	: 100,000 operations at rated current
Expected mechanical life	: 5 x 10 ⁶ operations

CONTROL RANGE

Target power factor	: 0.80 Inductive - 0.80 Capacitive
C/K setting	: 0.03 - 1.20 / Automatic detect
Sensitivity	: 5 - 300s
Switching program	: Automatic / manual / four-quadrant / rotational / linear
Rated step coefficient	: 0 / 1 / 2 / 3 / 4 / 5 / 6 / 8 / 12 / 16 / Fixed
Detection mode	: L1 / L2 / L3 / max Load / three phase
Fan setting	: Fixed on / output on / temperature / none
Signal contact	: Linked to 10 different programmable alarm / none

ALARM SETTING RANGE

% THDI	: 20% - 300% / OFF
Over voltage	: 253 - 264V / OFF
Under voltage	: 195 - 204V / OFF
Over current	: 5.50 - 7.00A / OFF
Under current	: 0.01 - 0.15A / OFF
Under compensate	: On / OFF
Over compensate	: On / OFF
*CT polarity error	: On / OFF
Step error	: On / OFF
Temperature	: 36 - 70 °C / OFF

*Only available for single phase model

DISPLAY

% THDI and THDV	: 0% - 500%
Harmonics resolution	: Up till 31st Harmonics
Active power	: 0 - 3000W
Reactive power	: 0 - 3000V AR
Apparent power	: 0 - 3000V A
Voltage	: 0 - 300V AC
Current	: 0.00 - 10.0 A rms
Temperature	: 0 - 100 °C
Frequency	: 45 - 65 Hz
Power factor	: -0.00 ind - 1.00 - 0.00 cap
Displacement power factor	: -1.00 - 1.00 (cap / ind)

MECHANICAL

Mounting type	: Panel mounting
Dimension(mm)	: 144 (W) x 144 (H) x 122 (L)
Enclosure protection	: IP54 at the panel
	: IP20 at the body
Approximate weight	: 1.2 kg (for three phase model)
	: 1kg (for single phase model)

ENVIRONMENT CONDITIONS

Temperature	: - 10°C to + 55 °C
Humidity	: 5% to 95%, non-condensing
Pollution degree	: II
Dielectric withstand	: IEC 61010-1

ELECTROMAGNETIC COPMPATABILITY (EMC)

Part 6-2: Generic standards	: IEC 61000-6-2
Immunity for industrial environment	
Part 6-4: Generic standards	: IEC 61000-6-4
Emission standard for industrial environment	

ORDERING INFORMATION

<u>MODEL</u>	<u>DESCRIPTION</u>	<u>MODEL</u>	<u>DESCRIPTION</u>
X80 PFR120P3-240-50	: 12 Step, 3 Phase, 240V AC, 50Hz Model	X80 PFR120P3-240-60	: 12 Step, 3 Phase, 240V AC, 60Hz Model
X80 PFR120P1-240-50	: 12 Step, 1 Phase, 240V AC, 50Hz Model	X80 PFR120P1-240-60	: 12 Step, 1 Phase, 240V AC, 60Hz Model
X80 PFR80P3-240-50	: 8 Step, 3 Phase, 240V AC, 50Hz Model	X80 PFR80P3-240-60	: 8 Step, 3 Phase, 240V AC, 60Hz Model
X80 PFR80P1-240-50	: 8 Step, 1 Phase, 240V AC, 50Hz Model	X80 PFR80P1-240-60	: 8 Step, 1 Phase, 240V AC, 60Hz Model